

Diamond Cabinet

DZ (type)

User Manual
Revision 1.0

1 Table of Contents

1.1 Sections

1	Table of Contents	2
1.1	Sections	2
1.2	List of Figures	3
1.3	List of Tables	4
2	Revision History	5
3	Overview	6
3.1	Dimensions	6
3.2	Operating Elements	10
3.3	Component description	11
4	Installation	12
4.1	Installation instructions	12
4.2	Base installation instructions	12
4.3	Power up	13
4.4	Safety precautions	13
4.4.1	Static-sensitive parts	13
4.4.2	Power off	13
4.4.3	Cabinet ventilation	13
4.4.4	Liquid	13
4.4.5	Avoid damages to the wires	13
4.4.6	Uncommon behavior	13
4.4.7	Wires	14
4.4.8	Environment	14
5	Power supply	15
5.1	Position in the machine	15
5.2	Removal	15
5.3	Characteristics	15
5.4	Connectors	16
5.4.1	DC Output Connector	16
6	Coin Acceptor	17
6.1	Function	17
6.2	Coins accepted	17
6.3	Error handling	17
6.4	Replacement	18
6.5	Connector	19
7	Bill Acceptor	20
7.1	Function	20
7.2	Bills accepted	20
7.3	Adjustment and troubleshooting	20
7.4	Error handling	20
7.4.1	Cleaning	23
7.4.2	Bill is jammed in bill acceptor	23
7.4.3	Bill is jammed near bill acceptor's entrance	24
7.5	Connectors	25
8	Ticket Printer	28
8.1	Position in the machine	28

8.2	Function	28
8.3	Error handling	29
8.4	Replacement.....	29
8.5	Connector.....	29
9	Hardware meters.....	30
9.1	Position in the machine.....	30
9.2	Functions.....	30
9.3	Troubleshooting	30
9.4	Meter replacement	30
10	Top Light (LCD topper)	32
10.1	Position in the machine	32
10.2	Function.....	33
10.3	Connector	33
10.4	Troubleshooting	33
10.5	Top light replacement.....	33
11	Button illumination.....	35
11.1	Position on the machine	35
11.2	Function.....	35
11.3	Troubleshooting	35
11.4	Button illumination replacement.....	35
12	Monitors	38
12.1	Position in the machine	38
12.2	Function.....	39
12.3	Troubleshooting	39
12.4	Monitor replacement	39
13	Audio amplifier	40
13.1	Function.....	40
13.2	Error handling	40
13.3	Replacement.....	40
13.4	Connectors.....	42
14	LED control board.....	44
14.1	Function.....	44
14.2	Connectors.....	45
15	Gaming platform D-PRO board	46
15.1	Function.....	46
15.2	Error handling	46
15.3	Replacement.....	47
16	Harness	48

1.2 List of Figures

Figure 1:	Machine dimensions with base	6
Figure 2:	Machine dimensions with top light and base	7
Figure 3:	Machine dimensions	8
Figure 4:	Machine base dimensions	9
Figure 5:	Machine operating elements	10
Figure 6:	Component description	11
Figure 7:	Machine mounting holes and dimensions.....	12
Figure 8:	DC output connector	16

Figure 9: Coin acceptor position in machine.....	17
Figure 10: Coin acceptor bracket position.....	18
Figure 11: Coin acceptor connector.....	19
Figure 12: Bill acceptor position in machine	21
Figure 13: Direction to remove bill acceptor.....	22
Figure 14: Bill acceptor cleaning.....	23
Figure 15: Jammed bill removal from bill acceptor stacker.....	24
Figure 16: Jammed bill removal from bill acceptor entrance.....	24
Figure 17: Hardware meter position in the machine	30
Figure 18: Hardware meter circuit board replacement.....	31
Figure 19: Top light position in machine	32
Figure 20: Top light replacement	34
Figure 21: Button panel with illuminated buttons Position on machine	35
Figure 22: Direction to change handle position	36
Figure 23: Button panel open position	37
Figure 24: Monitors position in machine	38
Figure 25: Monitor replacement.....	39
Figure 26: Audio amplifier position in machine	40
Figure 27: Audio amplifier connector description	42
Figure 28: Audio amplifier connectors pin layout	43
Figure 29: LED control board position in machine.....	44
Figure 30: Gaming platform board position in machine	46
Figure 31: Gaming platform board replacement	47
Figure 32: Audio connector.....	48
Figure 33: JCM UBA10 connector.....	48
Figure 34: Button and lamp connector 1	49
Figure 35: Button and lamp connector 2	49
Figure 36: Coin acceptor connector.....	50
Figure 37: Coin hopper connector	50
Figure 38: iButton connector.....	50
Figure 39: Key and door switch connector.....	51
Figure 40: Hardware meter connector	51
Figure 41: Top light connector	52
Figure 42: Power supply unit connector.....	53

1.3 List of Tables

Table 1: DC Output Connector Pin Layout.....	16
Table 2: Accepted coin table	17
Table 3: Coin Acceptor Connector Pin Layout	19
Table 4: Accepted bill table.....	20
Table 5: Bill Acceptor JCM: UBA 10 and IPRO Connector Pin Layout.....	25
Table 6: Bill Acceptor JCM IVizion Connector Pin Layout.....	26
Table 7: Bill Acceptor Mei SC Advance Connector Pin Layout	27
Table 8: Ticket printer GEN2U/GEN5_RS232 / Epic 950 RS232 Connector Pin Layout.....	29
Table 9: Top light Connector Pin Layout.....	33
Table 10: LED PCB Mode Selection	45

2 Revision History

Version	Date	Author	Description
1.0	2017.03.07	DLV	Initial document release

3 Overview

3.1 Dimensions

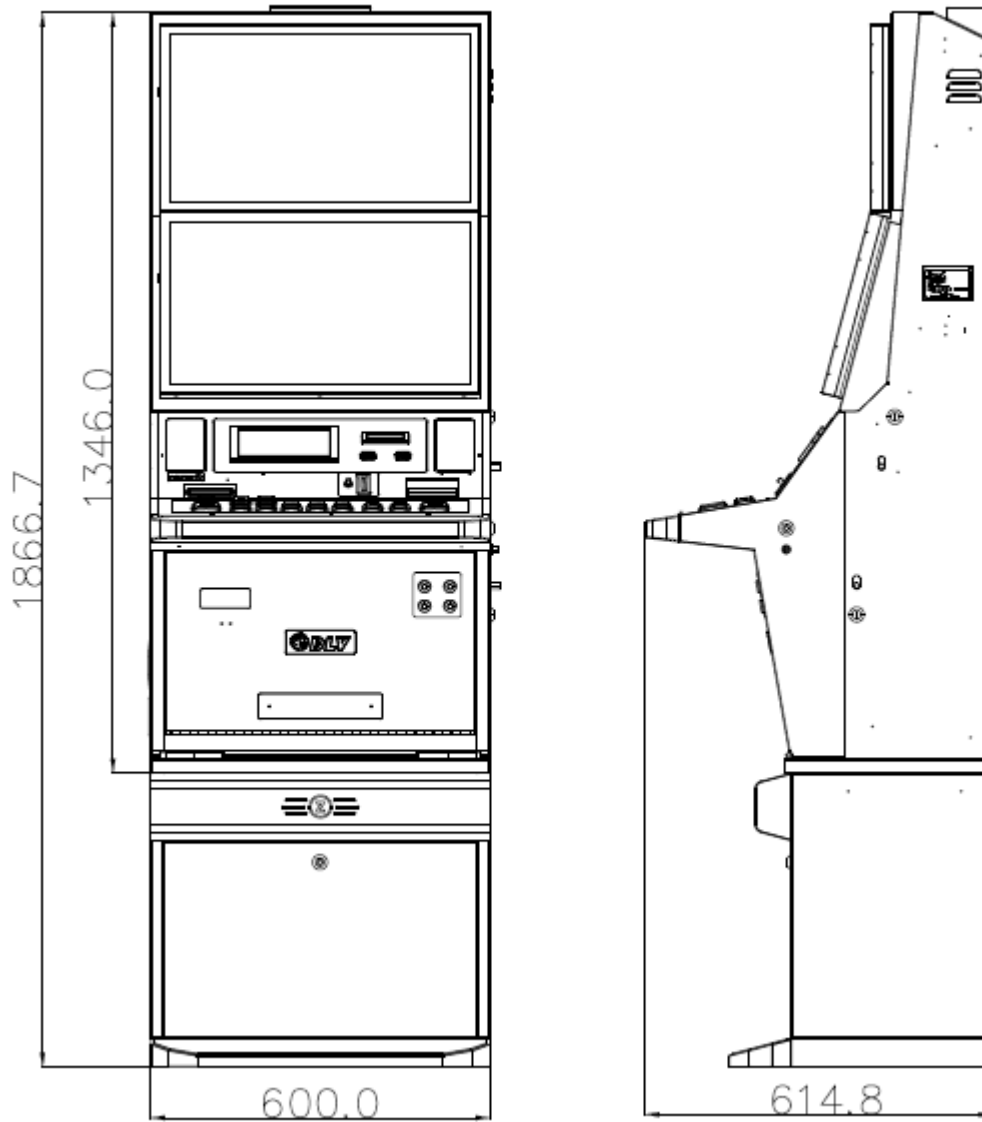

Figure 1: Machine dimensions with base

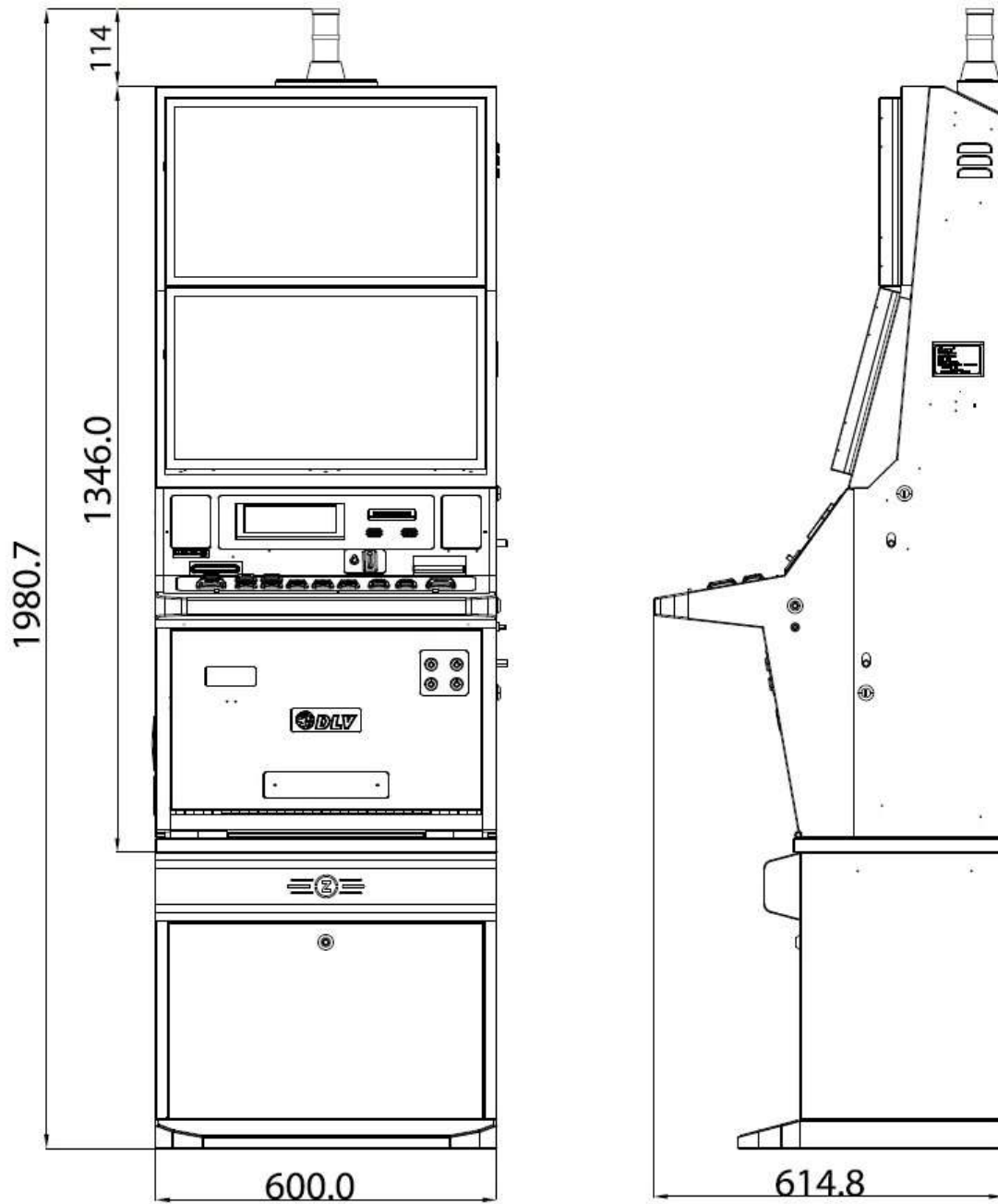

Figure 2: Machine dimensions with top light and base

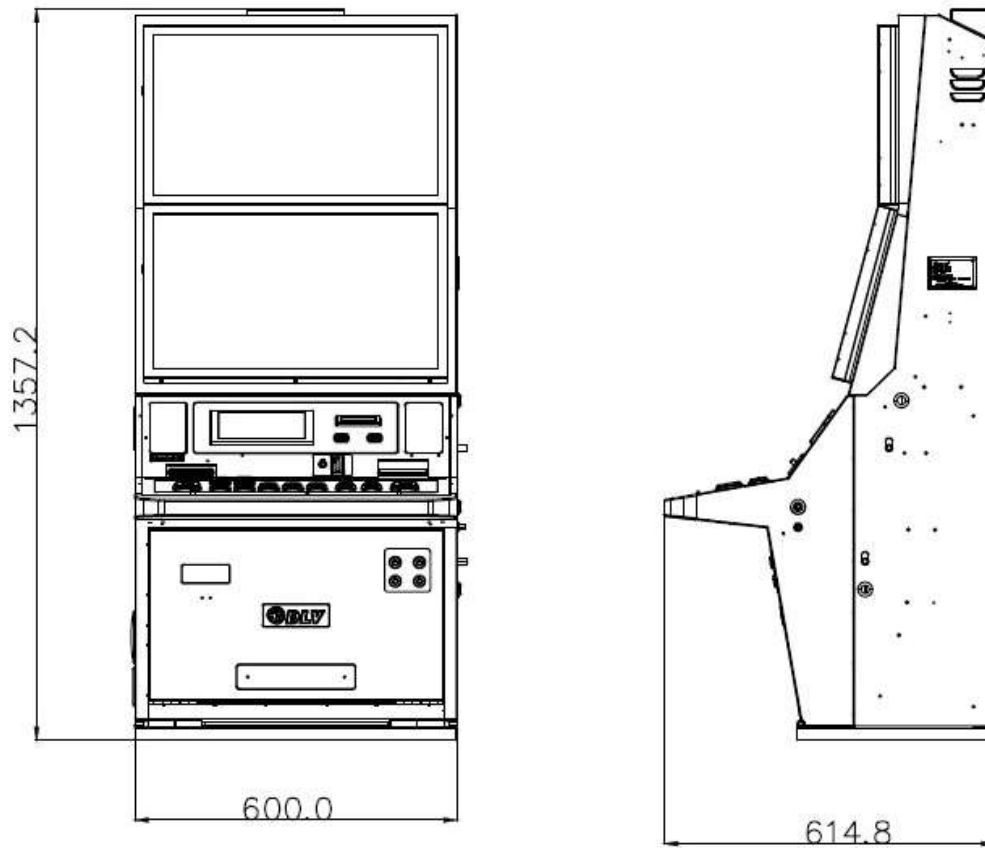

Figure 3: Machine dimensions

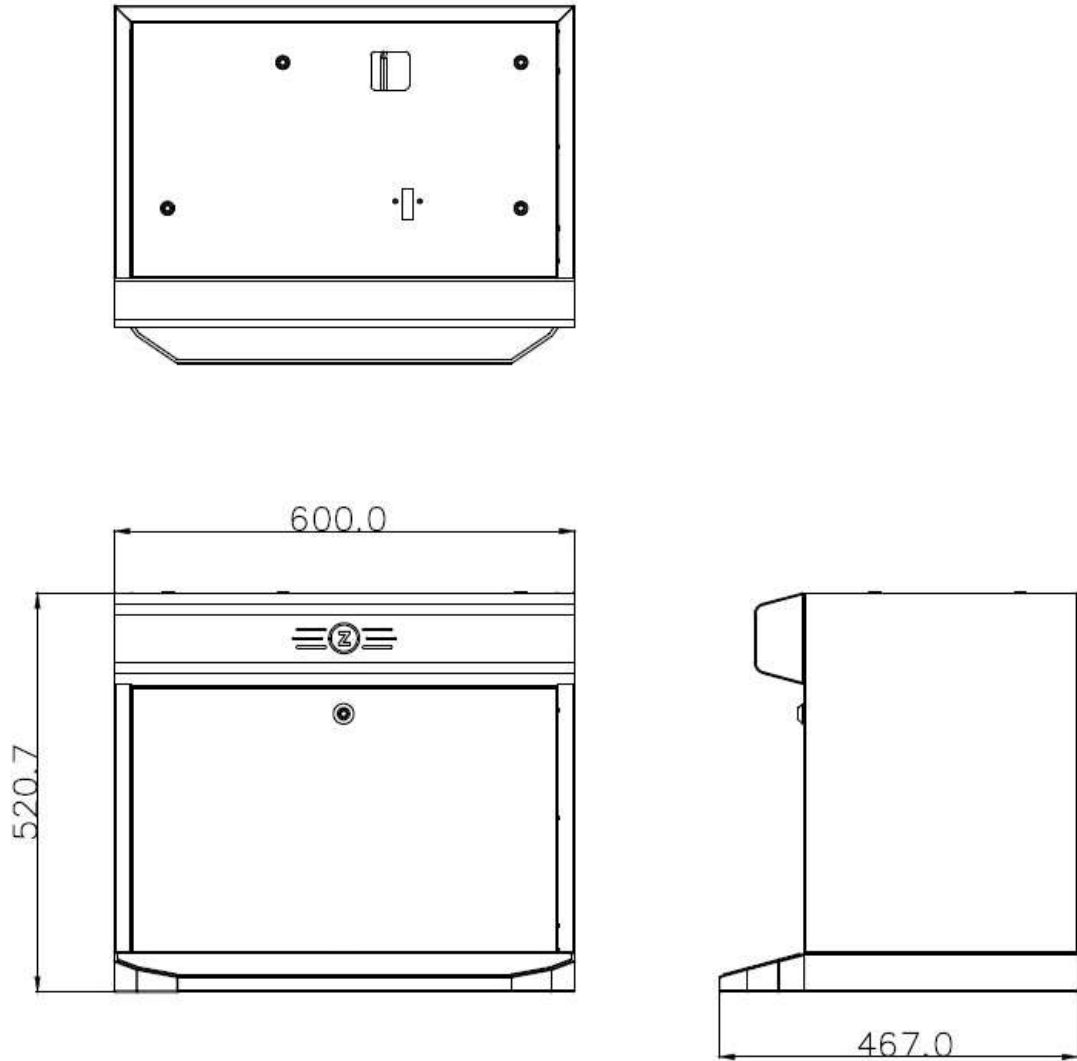

Figure 4: Machine base dimensions

3.2 Operating Elements

1. Coin entry
2. Bill entry
3. Main door lock
4. Monitor door lock
5. Coin tray
6. Acces key switches
7. Button panel
8. Top light plate

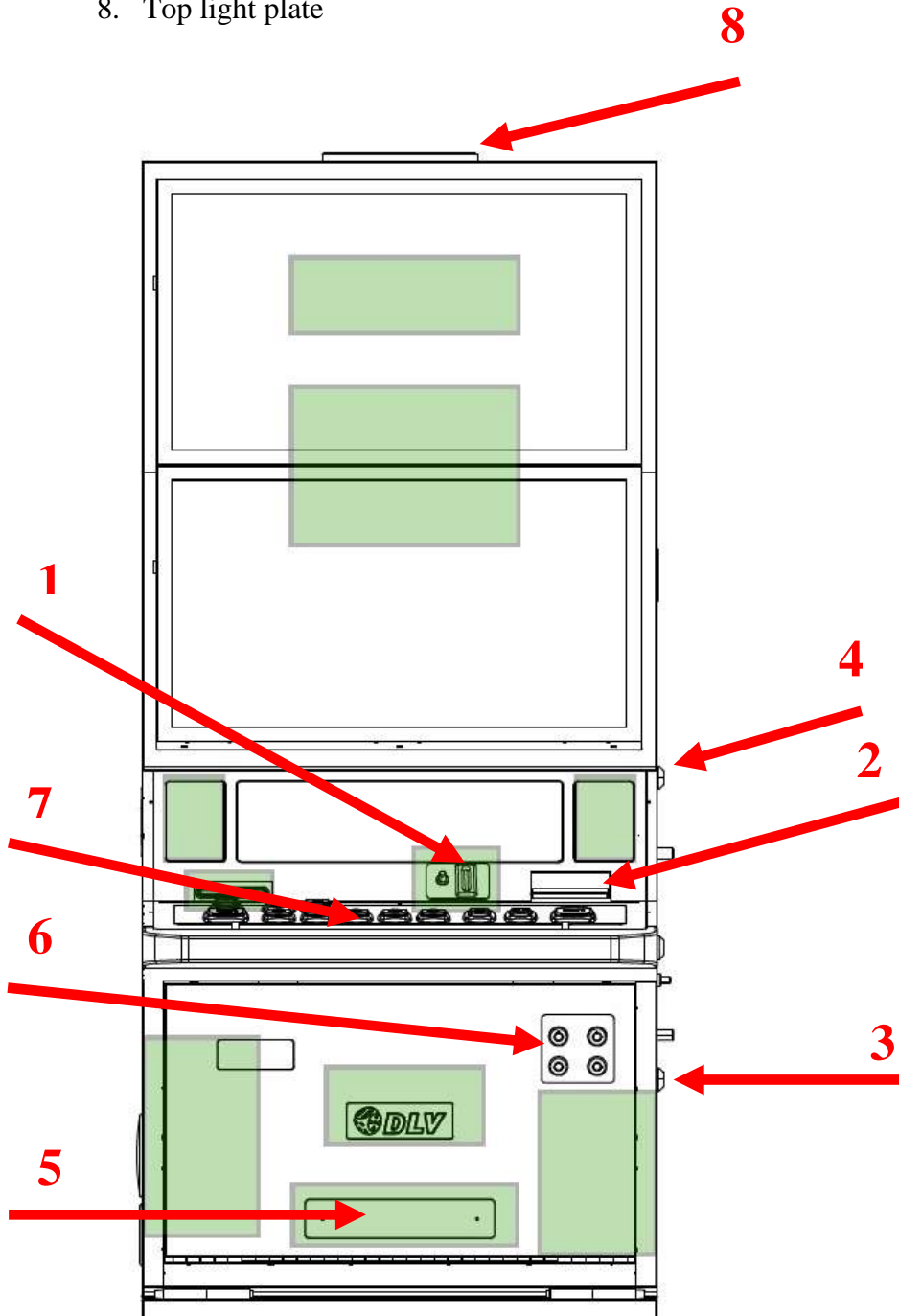

Figure 5: Machine operating elements

3.3 Component description

1. Monitors
2. Game PCB
3. Power Supply Unit
4. Power Supply Main
5. Bill Acceptor
6. Coin Acceptor
7. Loudspeaker
8. Subwoofer
9. Sound Amplifier
10. Ticket Printer

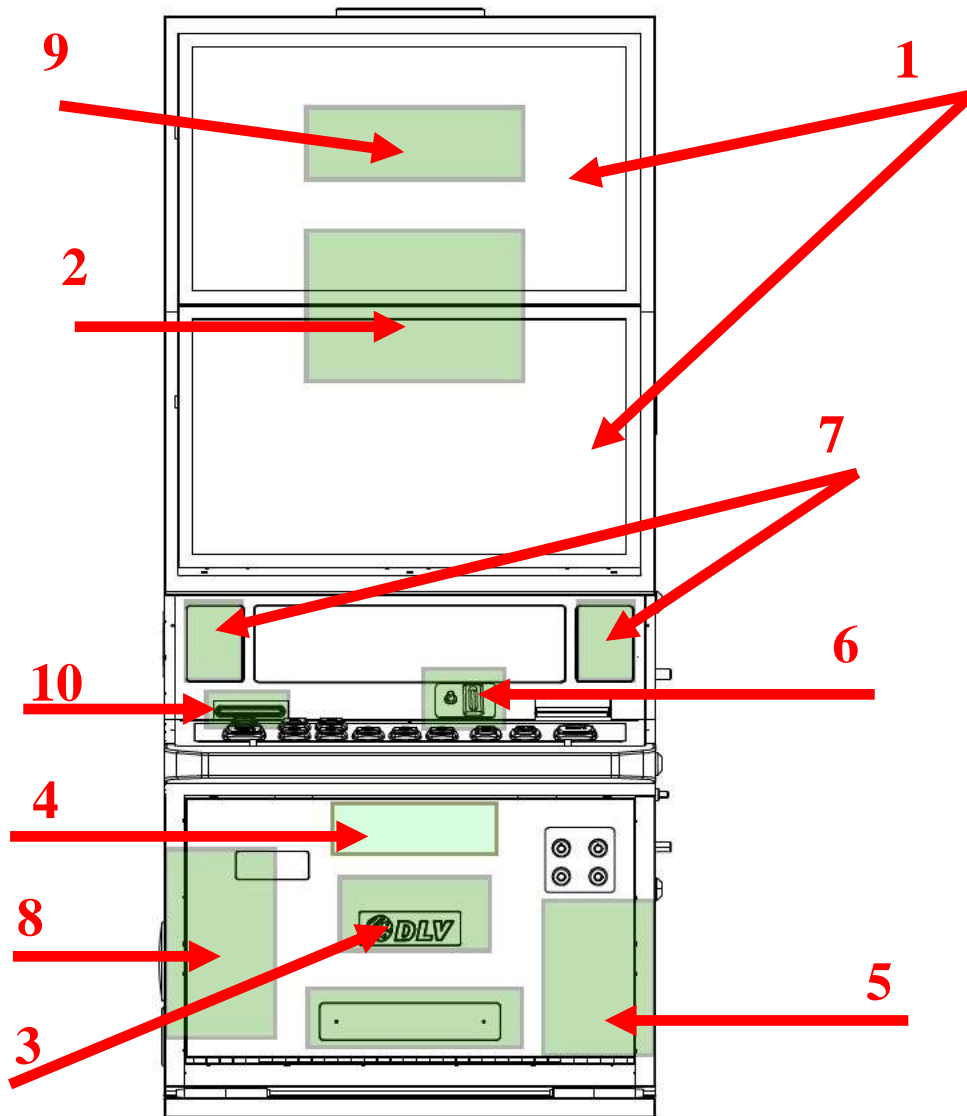

Figure 6: Component description

4 Installation

4.1 Installation instructions

The machine should be operated in upright position.

The minimum distance between two machines should be 10 cm to avoid possible damage when opening the main door. The minimum distance to a possible back wall or the like should be 10 cm.

4.2 Base installation instructions

The machine should be operated in upright position.

The machine should be screwed tightly to the base using the mounting material included in the delivery. The minimum distance to a possible back wall or the like should be 10 cm. Mounting holes (figure 6) should be used in case if the machine is to be installed on a table provided by customer (the machine has been delivered without a base).

All dimensions are in mm.

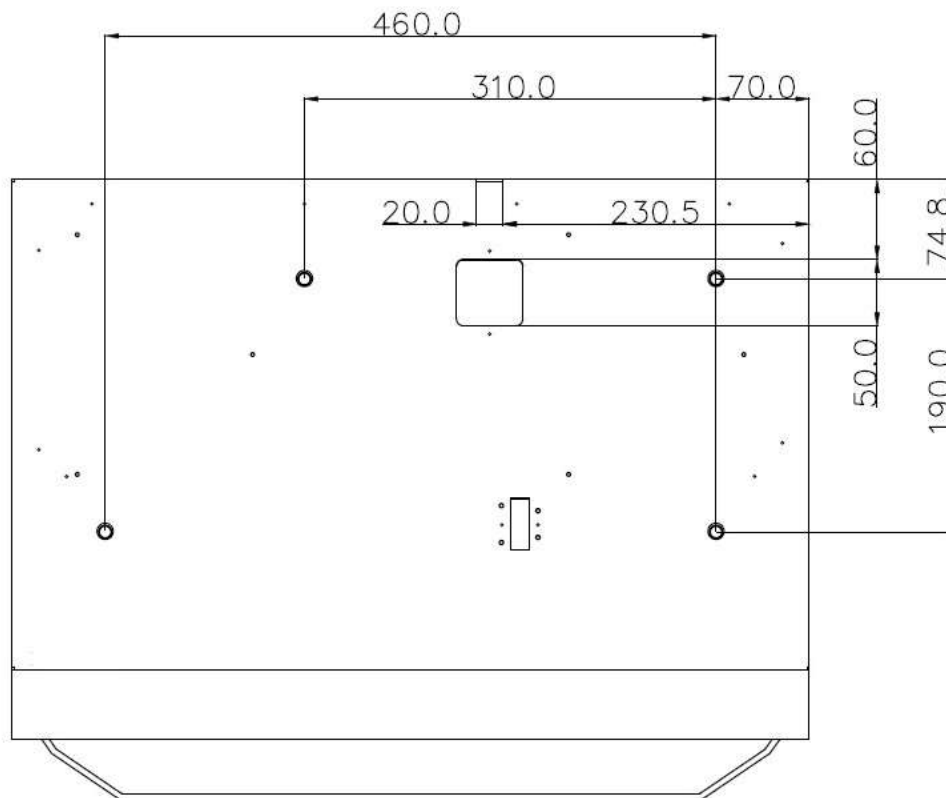

Figure 7: Machine mounting holes and dimensions

4.3 Power up

Before start, check line voltage and grounding. The machine is designed to operate at 100~120V/200~240V, 50-60Hz.

AC power outlet to which the machine is connected should be easily accessible in case of emergency.

4.4 Safety precautions

This section is designed to avoid damage to the machine and to minimize damage and protect maintenance personnel and users from electric shock.

ATTENTION:

The following service instructions are to be used by qualified or trained personnel only. The appliance is not to be used by persons with reduced physical, sensory or mental capabilities, or lack of experience and knowledge, unless they are supervised or instructed, and children are prevented from playing with the appliance.

4.4.1 Static-sensitive parts

The machine contains static-sensitive components which could be damaged by electric discharges. Prior maintenance of the machine's internal components, always touch ground straps inside the machine to neutralize electric charges.

4.4.2 Power off

In case of emergency, power off the machine!

The machine will be completely powered off only when AC plug is removed from the outlet.

If the machine is connected to an uninterruptible power supply, be sure to switch it off.

WARNING: Unplugging the machine with wet hands or in wet environment may cause electric shock.

4.4.3 Cabinet ventilation

Do not block or insert any objects into ventilation holes. This may cause the machine to overheat or result in risk of fire or electric shock.

Secure proper space between machine and other objects to allow for normal ventilation conditions.

4.4.4 Liquid

Avoid spilling on the machine any kind of liquids. **Never clean the machine with a water jet.** This may result in risk of fire or electric shock. In case of accident, unplug the machine immediately and contact qualified technical staff.

4.4.5 Avoid damages to the wires

Damaged power cord can result in risk of fire or short circuit. If the power cord is damaged, it must be replaced with a special cord provided by the manufacturer or its agent.

4.4.6 Uncommon behavior

If there are unusual sounds, lights or smells coming out of the machine, power off the machine completely and contact qualified technical staff. Failure to do so may result in risk of fire.

4.4.7 Wires

Make sure that no wires inside and outside the machine are damaged, squeezed or stretched. Also make sure that the wire near AC plug is not frayed. Damaged wires may cause short circuit or fire risk.

4.4.8 Environment

The machine is suitable for indoor use only!

Do not expose the machine under any circumstances to wet environments or temperatures greater than 50°C.

After transportation or storage in cold environments do not power up the machine right away, wait for the machine to reach its normal operating temperature.

The recommended operating temperature is between 10°C and 35°C, and relative humidity of 30% to 80% (non-condensing).

Do not install machine near heaters or other electronic devices that produce a lot of heat or dust. Failure to do so can result in risk of machine malfunction, overheat or fire.

5 Power supply

5.1 Position in the machine

Power supply is located on the backside (as shown in the picture).

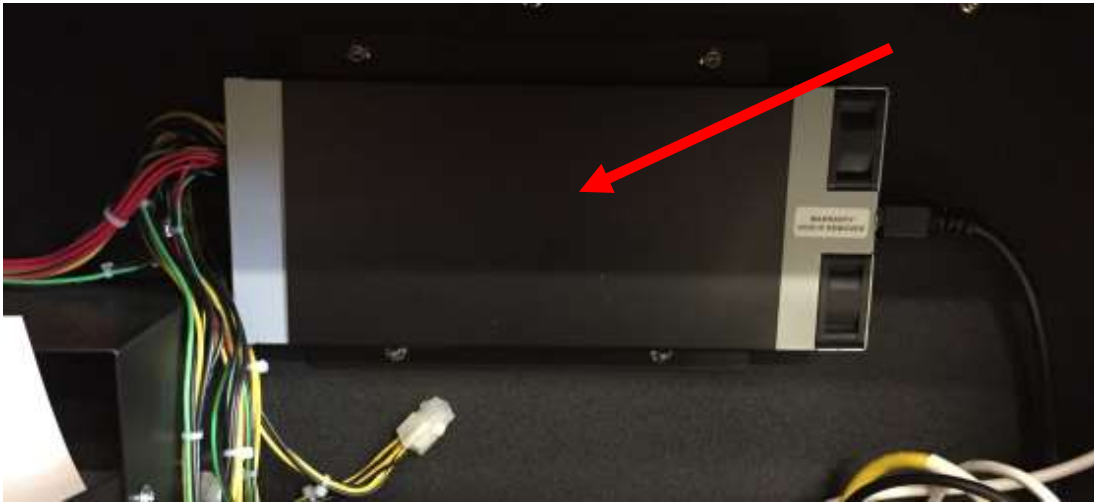

5.2 Removal

To remove the power supply, disconnect all the wiring and unscrew four nuts that hold the power supply in place (shown with red arrows).

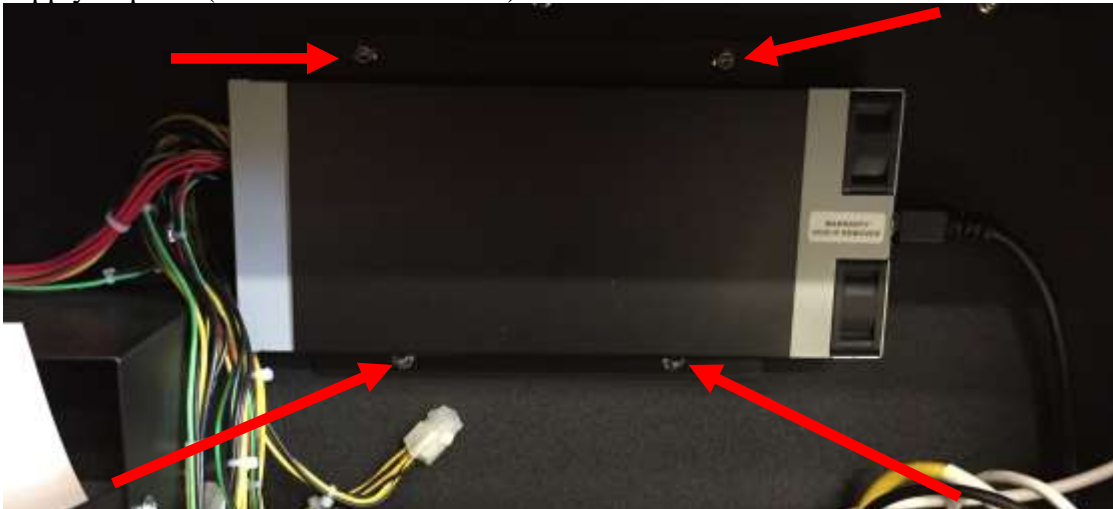

5.3 Characteristics

Type	Hsuan-I International
Model	RP-3863-00
Input	100-240V~ , 47Hz-63Hz
Output	+5V:6A
Output	+12V:20.5A
Output	+24V:4.7A
Output watt	386 W

5.4 Connectors

5.4.1 DC Output Connector

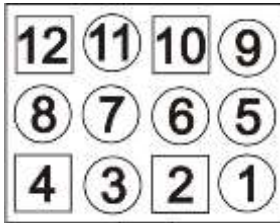

Figure 8: DC output connector

Pin No.	Color	Description
4, 8, 12	RED	+5V
5, 9	YELLOW	+12V
7, 11	GREEN	+24V
2, 3, 6, 10	BLACK	GND

Table 1: DC output connector pin layout

6 Coin Acceptor

6.1 Function

Type **NRI G-13 mft (parallel or CCTalk mode)** or compatible coin acceptor with up to 6 pre-programmed coin channels

Coins drop directly to cash box.

6.2 Coins accepted

The machine accepts the following coins:

Country	Coin value
Latvia	1 EUR

Table 2: Table of coins accepted

6.3 Error handling

1. Unplug the machine and open the main door;
2. Check whether the coin acceptor is properly positioned, remove any jammed coins;
3. Ensure that the coin acceptor cable is properly connected to the device;

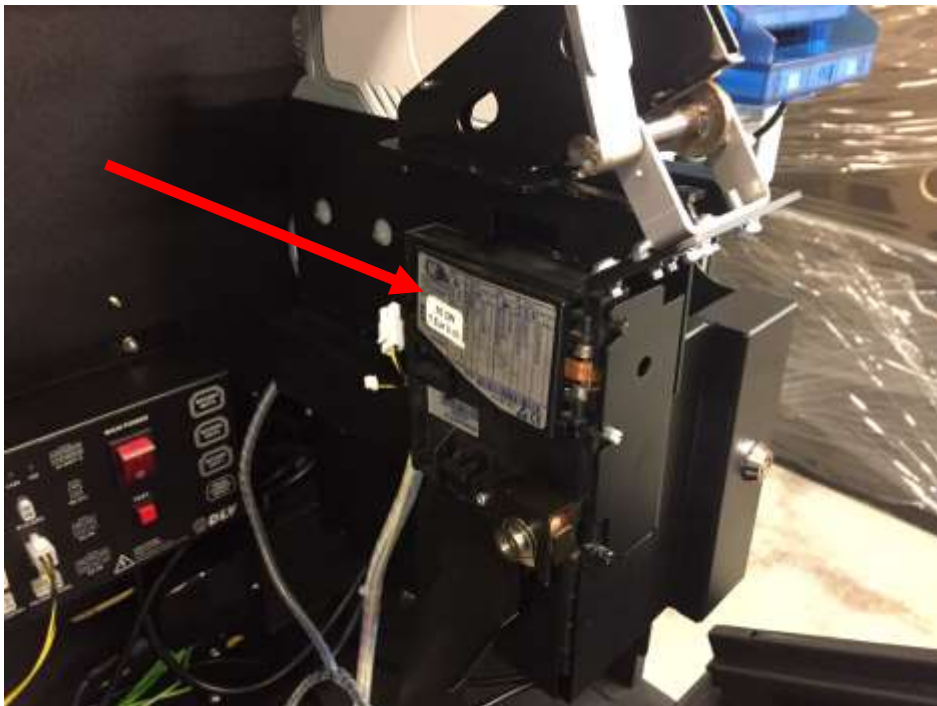

Figure 9: Coin acceptor position in machine

6.4 Replacement

If a coin acceptor cannot be fixed in-place, the complete device should be replaced.

1. Unplug the machine and open the main door;
2. Tilt the upper part of the coin acceptor first, and then remove the coin acceptor from the bracket;
3. Unplug the cable;
4. Repeat the steps above in the reverse order;

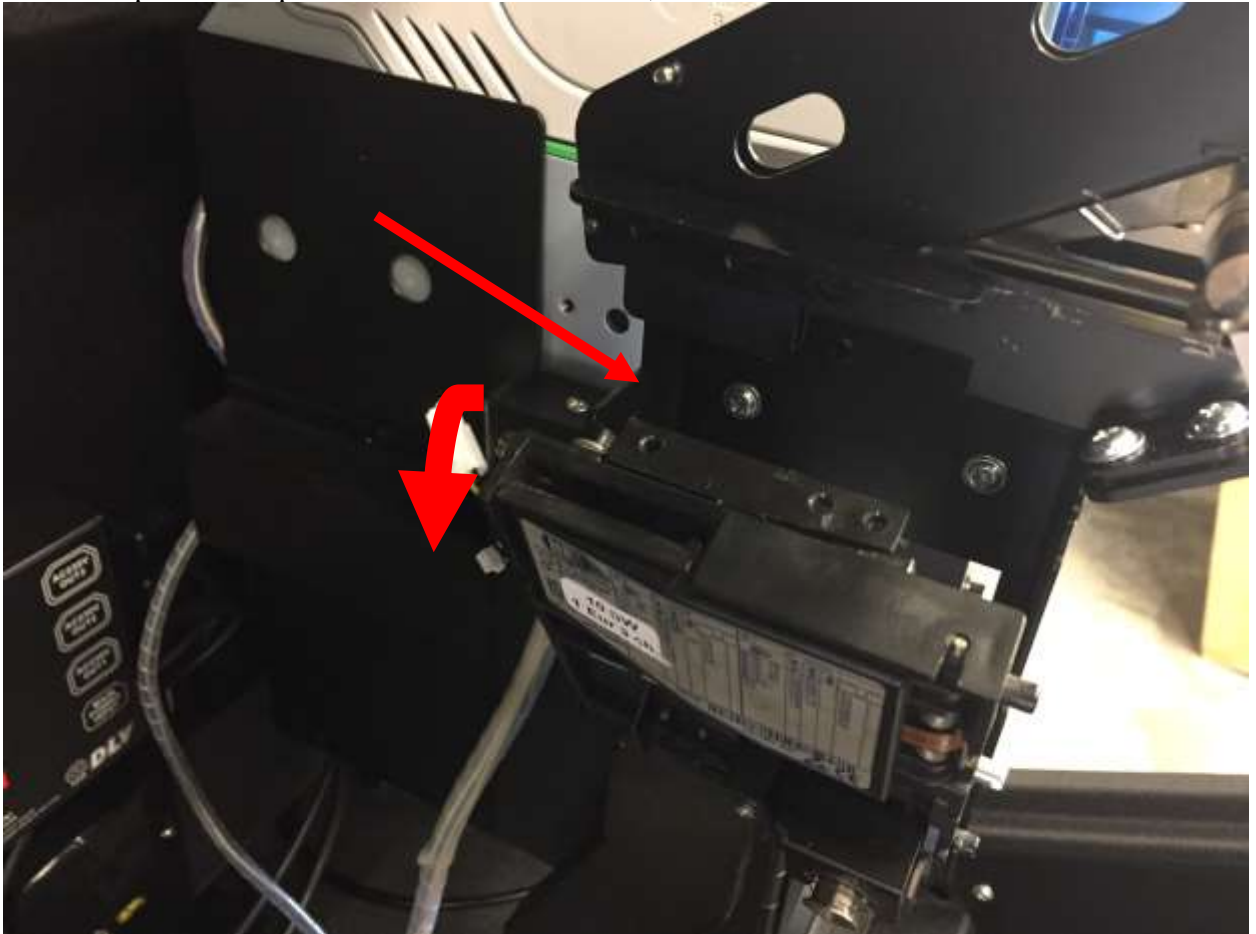

Figure 10: Coin acceptor bracket position

6.5 Connector

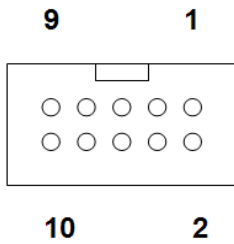

Figure 11: Coin acceptor connector

Pin No.	Description	Potential
1	GND	Low
2	+12V DC	High
3	Coin E	Active low
4	Coin F	Active low
5	Return	Active low
6	Common inhibit	Active high
7	Coin A	Active low
8	Coin B	Active low
9	Coin C	Active low
10	Coin D	Active low

Table 3: Coin Acceptor Connector Pin Layout

7 Bill Acceptor

7.1 Function

Type JCM UBA, iPRO, iVizion/Cash Code / MEI Cashflow

Bill validators accept bills in all 4 directions and tickets. Any country settings can be adjusted by changing flash memory software.

7.2 Bills accepted

The machine accepts and handles the following bills

Country	Bill value
Latvia	5 EUR
	10 EUR
	20 EUR
	50 EUR
	100 EUR
	200 EUR
	500 EUR

Table 4: Table of bills accepted

7.3 Adjustment and troubleshooting

Check with voltmeter whether the power supply output current is +12V or +24V (depends on BA model).

In case of machine short circuit, the power supply switches off automatically.

Switch the machine back on after repairing short circuit. In most cases, the power supply unit will work properly again (yellow light).

7.4 Error handling

1. Unplug the machine and open the main door;
2. Move forward the bill acceptor head
3. Check whether the bill acceptor is properly positioned, remove any jammed notes;



Figure 12: Bill acceptor position in machine

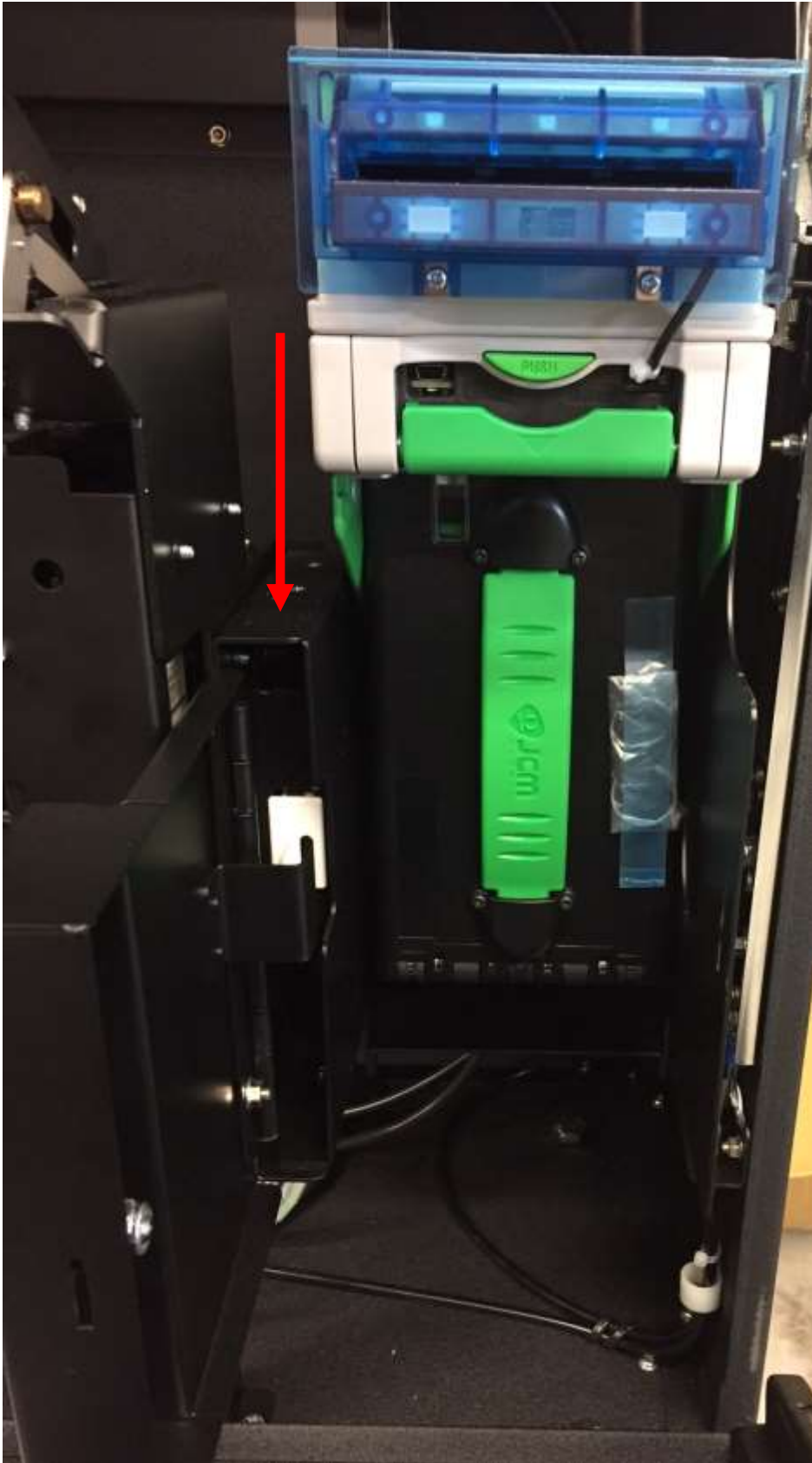

Figure 13: Direction to remove bill acceptor

7.4.1 Cleaning

To clean the lenses, use a lint-free cloth and mild nonabrasive detergent such as liquid dish soap mixed with water.

1. Pull the tabs on both sides of the acceptor ejected to open the acceptor's head;
2. Open the acceptor head front and rear covers to clean bill path, rollers and belts.

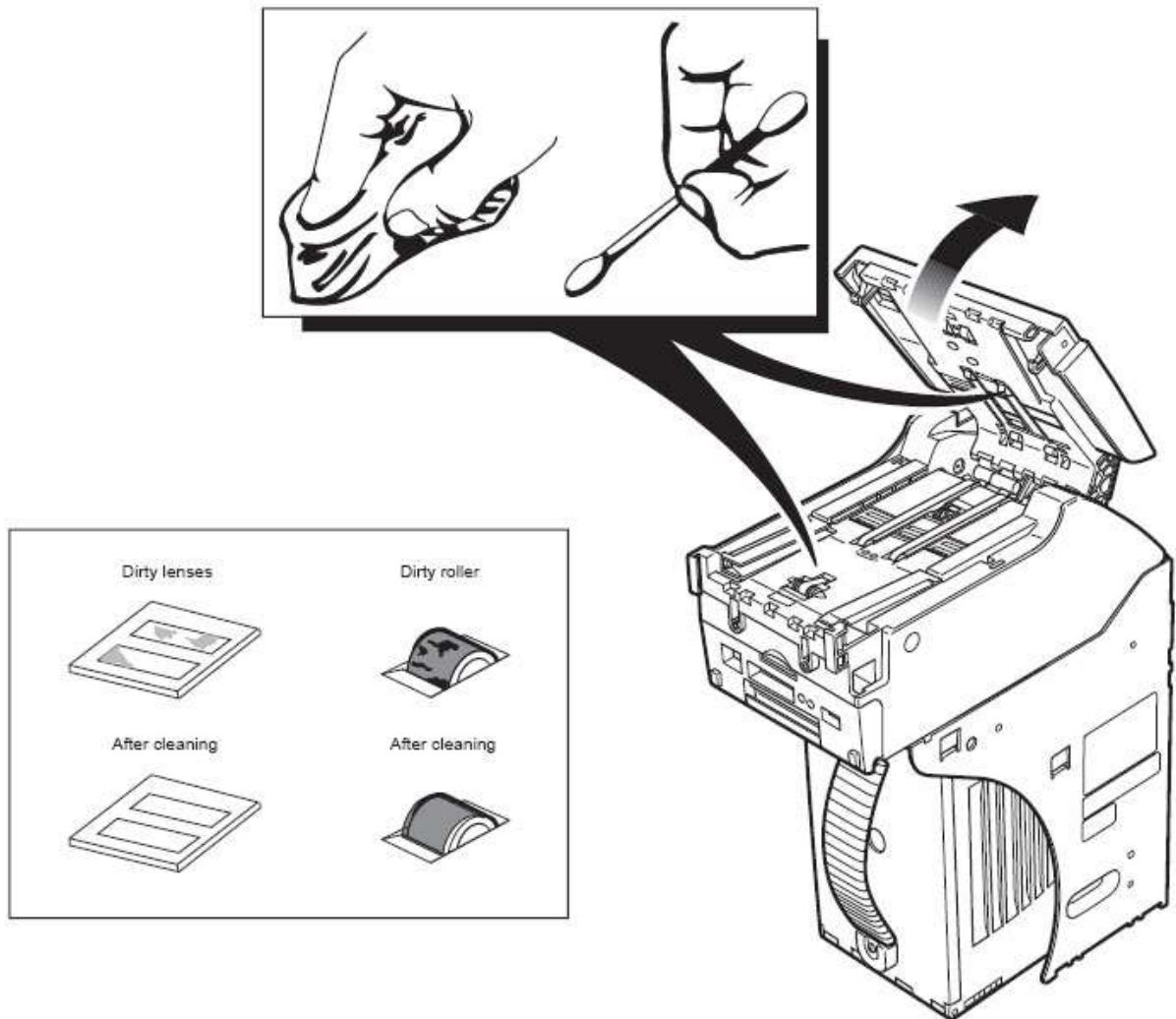

Figure 14: Bill acceptor cleaning

7.4.2 Bill is jammed in bill acceptor

When a bill is jammed near the stacker box entrance, unlock the box and pull it out to remove the jammed bill.

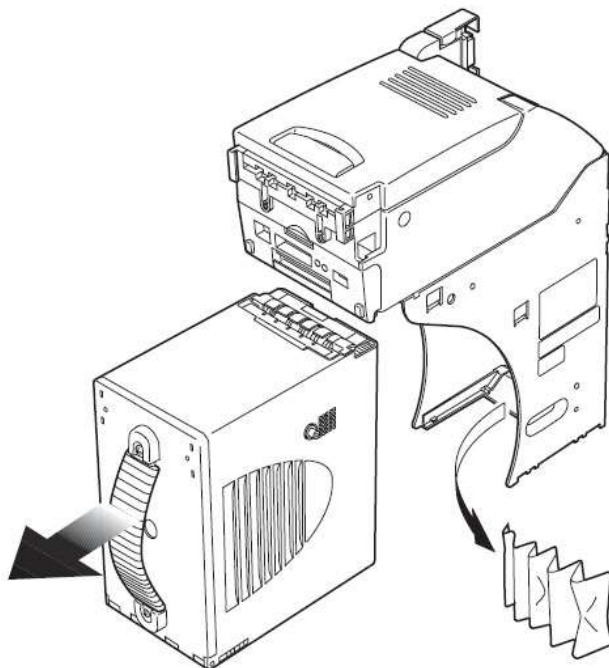

Figure 15: Jammed bill removal from bill acceptor stacker

7.4.3 Bill is jammed near bill acceptor's entrance

When a bill is jammed near bill acceptor's entrance, pull the tabs on the top of the bill acceptor to open the cover of the bill acceptor unit. Remove the jammed bill.

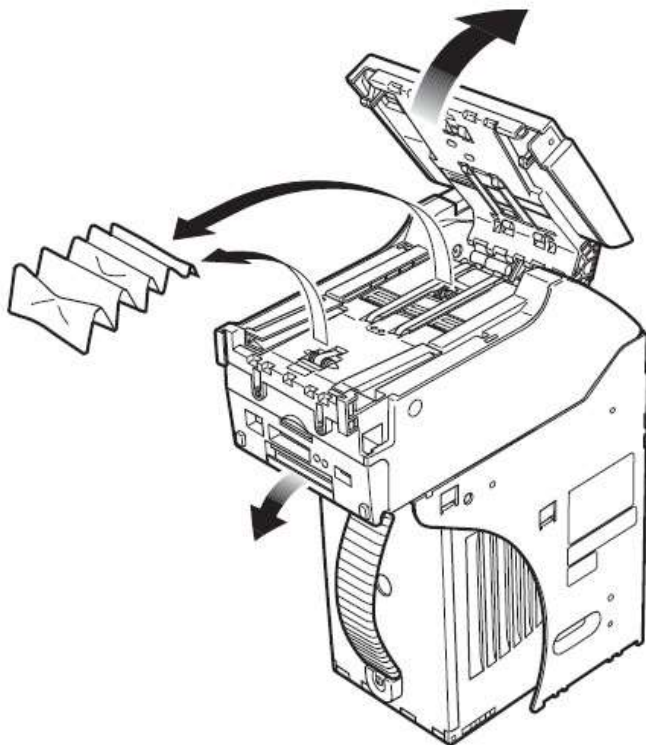

Figure 16: Jammed bill removal from bill acceptor entrance

7.5 Connectors

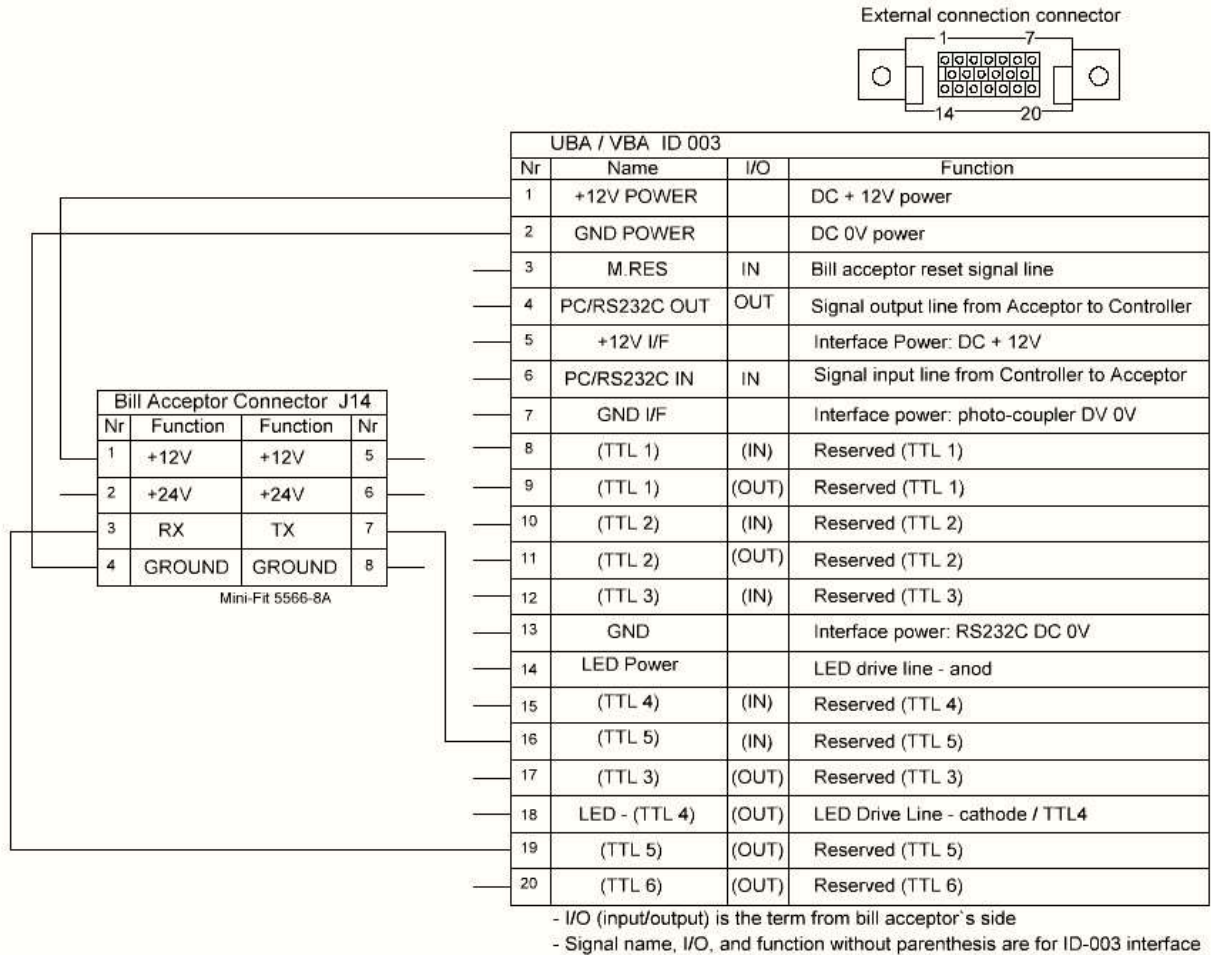

Table 5: Bill Acceptor JCM: UBA 10 and IPRO Connector Pin Layout

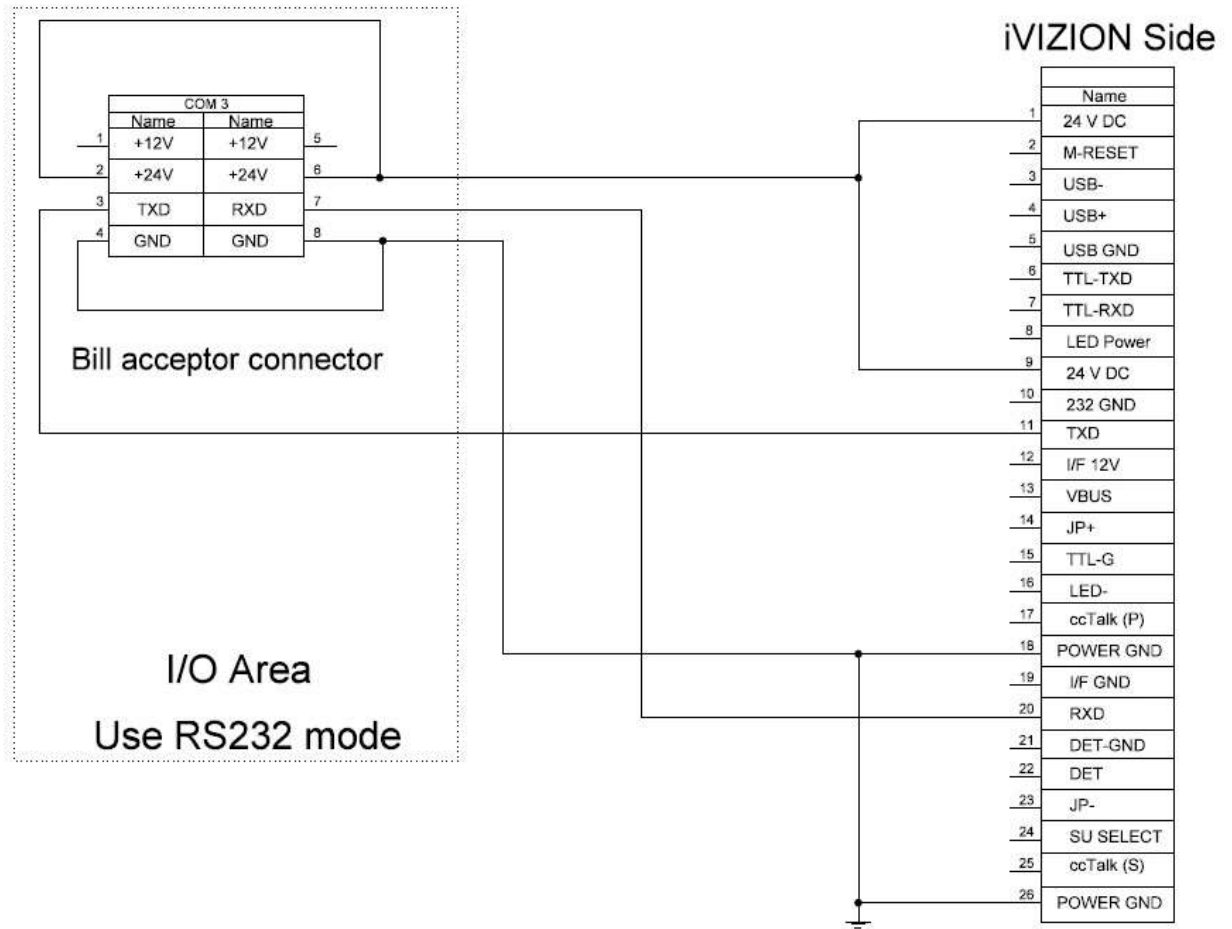

Table 6: Bill Acceptor JCM iVizion Connector Pin Layout

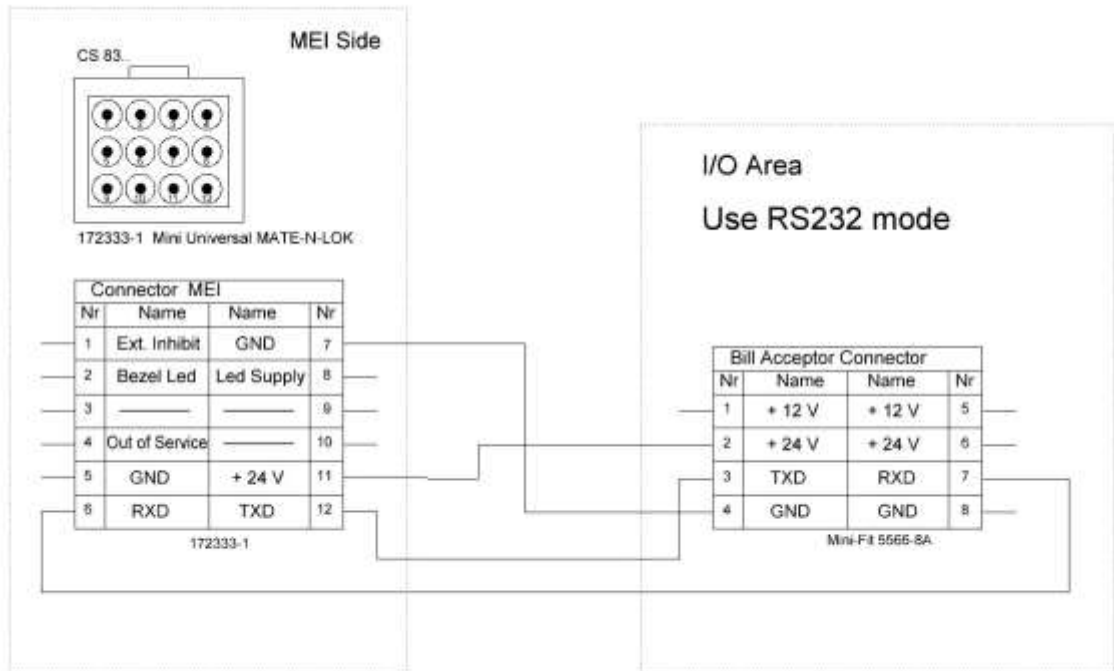
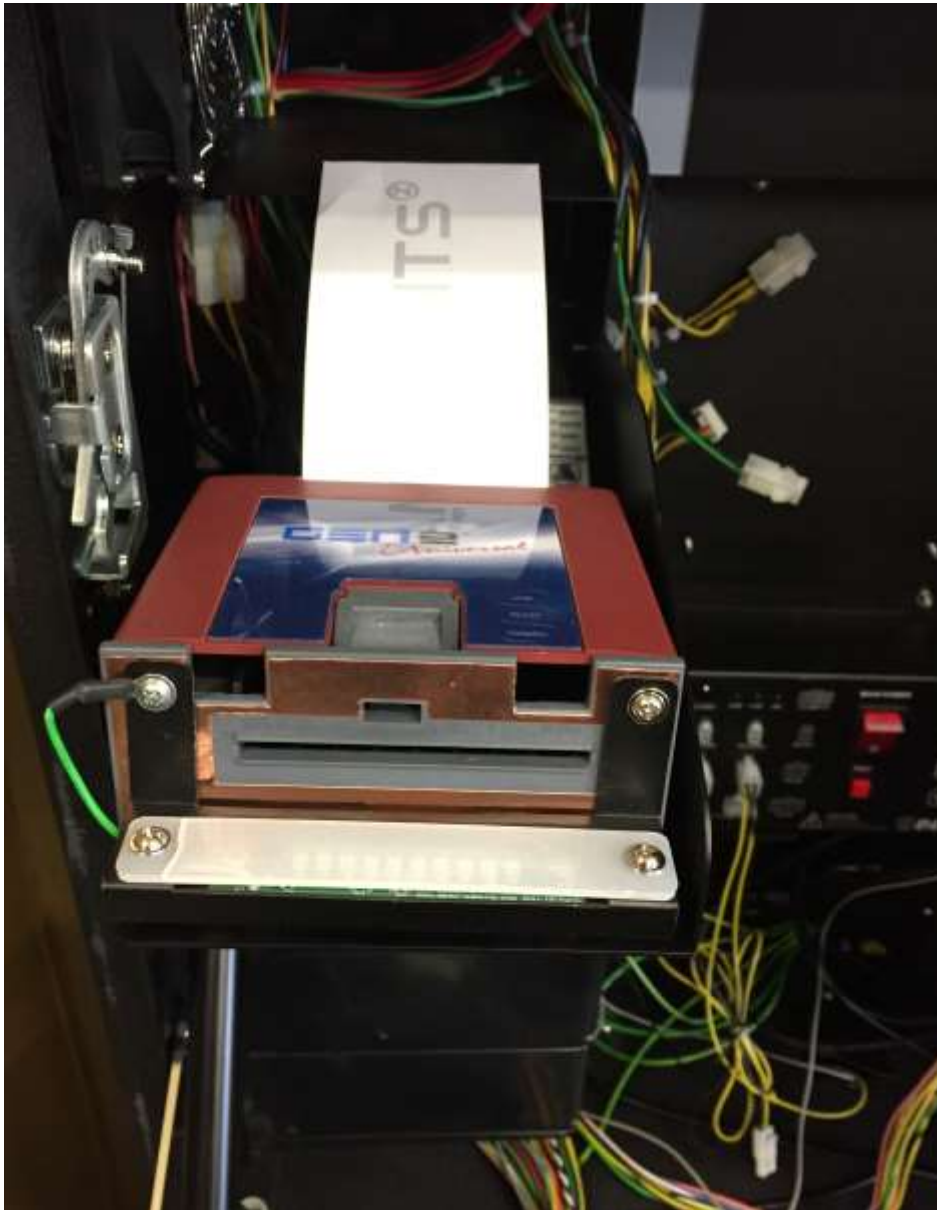

Table 7: Bill Acceptor MeI SC Advance Connector Pin Layout

8 Ticket Printer

8.1 Position in the machine

Ticket printer is located above subwoofer (as shown in the picture).



8.2 Function

Model/Type

- **FutureLogic GEN2U / GEN5**
- **TransAct Epic 950**

Players can print out a ticket with the remaining credits by pressing Payout button on the machine. The ticket can be redeemed at a cash desk or by inserting it into a bill acceptor; the ticket value will be shown in the credit area on the machine screen.

8.3 Error handling

1. Unplug the machine and open the main door
2. Check the plug fitting
3. Check the power supply of the printer and plug connection to the backplane
4. Switch on the machine.
5. When the program has been loaded, enter Service menu → Diagnostics → Ticket Printer Test, and print a test ticket.

8.4 Replacement

To remove a ticket printer: open the main door, disconnect all the wiring and unscrew the screws that hold the ticket printer in place.

8.5 Connector

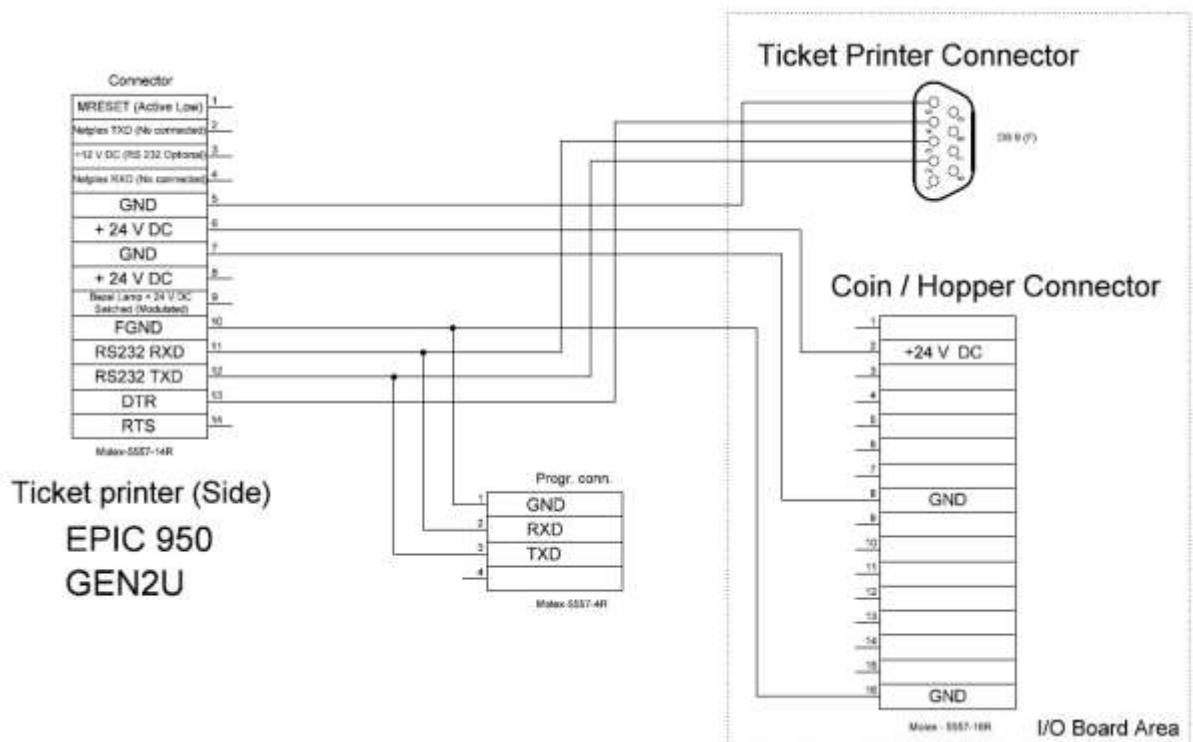

Table 8: Ticket printer GEN2U/GEN5_RS232 and Epic 950 RS232 Connector Pin Layout

9 Hardware meters

9.1 Position in the machine

Hardware meters are mounted on the right side of the belly door.



Figure 17: Hardware meter position in the machine

9.2 Functions

1. CREDITS WAGERED
2. CREDITS WON
3. GAMES PLAYED
4. BILL IN
5. COIN DROP
6. HANDPAY

9.3 Troubleshooting

1. Check meter unit connections.
2. If an error message is triggered by malfunction or non-activation of an individual meter, the device must be removed from operation and the meter circuit board must be replaced.

9.4 Meter replacement

If there are defects that cannot be repaired, the defective meter has to be replaced.

1. Unplug the machine and open the belly door;
2. Unscrew the nuts as shown in the picture;
3. Remove the meter circuit board;
4. Unplug the cable from the meter circuit board;

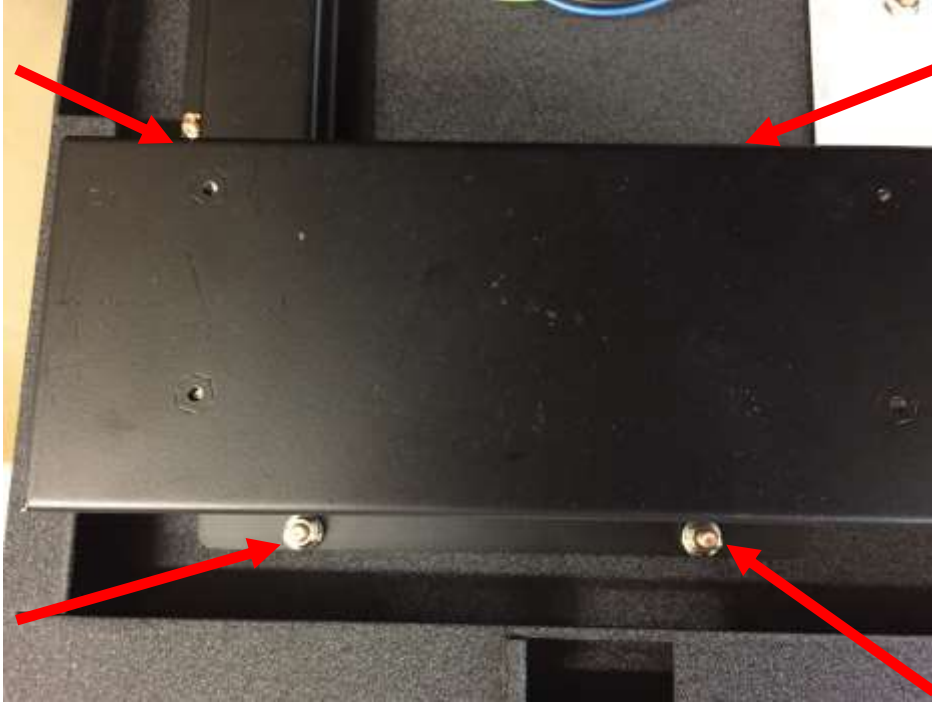

Figure 18: Hardware meter circuit board replacement

10 Top Light (LCD topper)

10.1 Position in the machine



Figure 19: Top light position in machine

10.2 Function

Top light shows different operation statuses (jackpot, errors, service)

10.3 Connector

Pin No.	Color	Function
1	White	+12V DC
2	Red	Top light (RED)
3	Yellow	Top light (YELLOW)
4	-	NC

Table 9: Top light Connector Pin Layout

10.4 Troubleshooting

Check whether the top light (LCD topper) and cable connectors are properly fixed in their mounting.

10.5 Top light replacement

If there are defects that cannot be repaired, the defective top light has to be replaced.

1. Unplug the machine and open the monitor door;
2. Unscrew the screws as shown in picture (with red arrows).
3. Remove the top light plate;



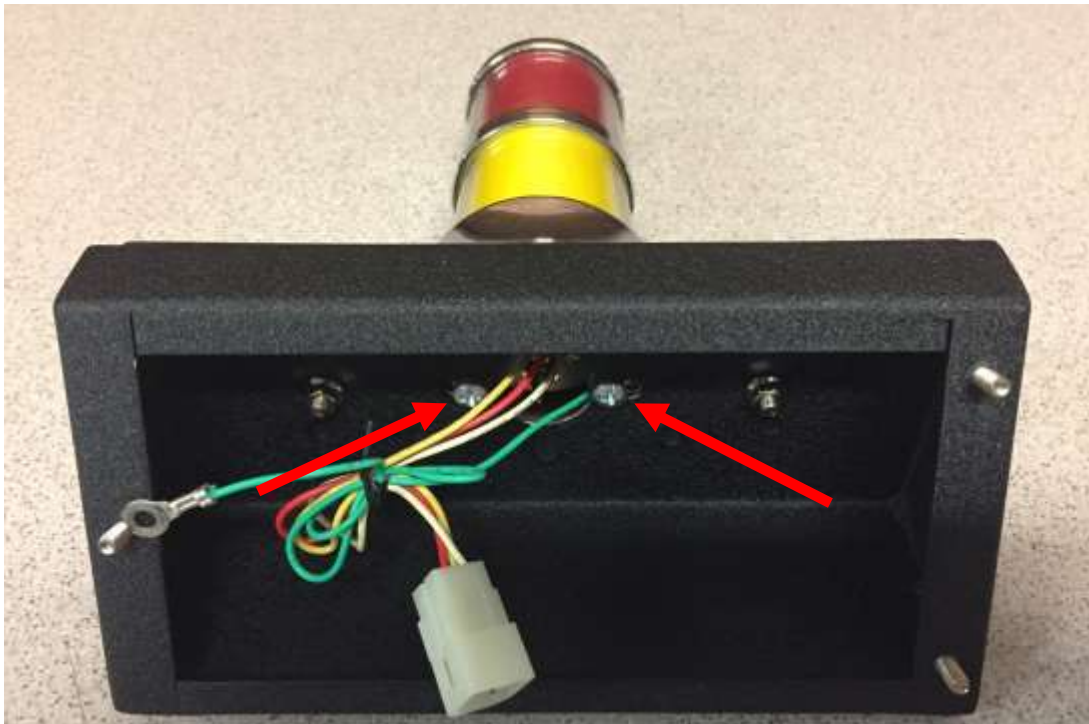

Figure 20: Top light replacement

11 Button illumination

11.1 Position on the machine



Figure 21: Button panel with illuminated buttons Position on machine

11.2 Function

Button illumination shows active buttons during game play. Audit Menu functions can be activated via respectively illuminated buttons.

11.3 Troubleshooting

If there are defects that cannot be repaired, the defective button illumination has to be replaced.

11.4 Button illumination replacement

1. Unplug the machine and open the belly door;
2. Push the yellow handle (shown with green arrow) and open the button panel door.
3. Turn down the led base of the defective led and take out the led.
4. Replace the led, press the base into the bracket and close the button panel door.

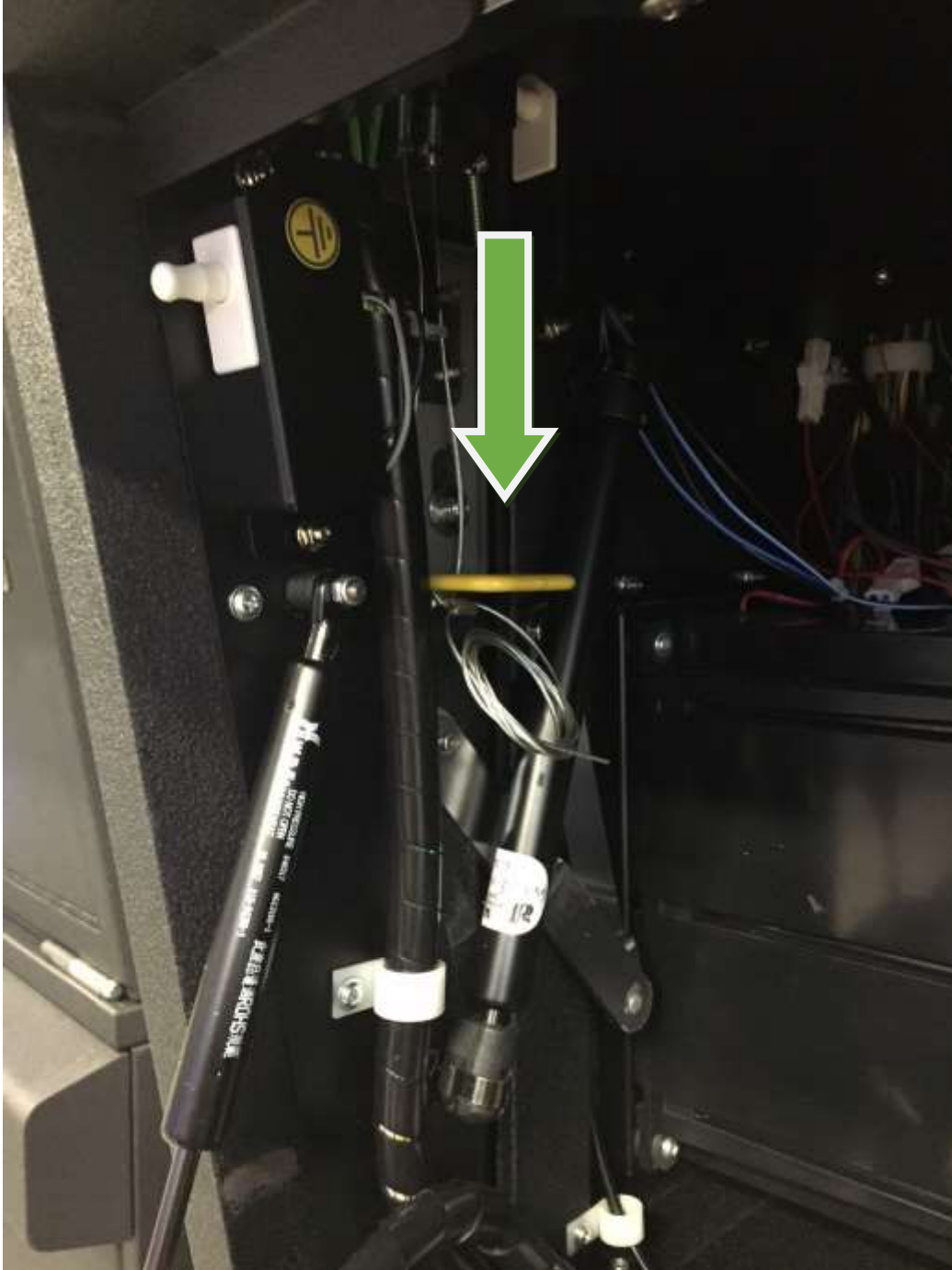

Figure 22: Direction to change handle position

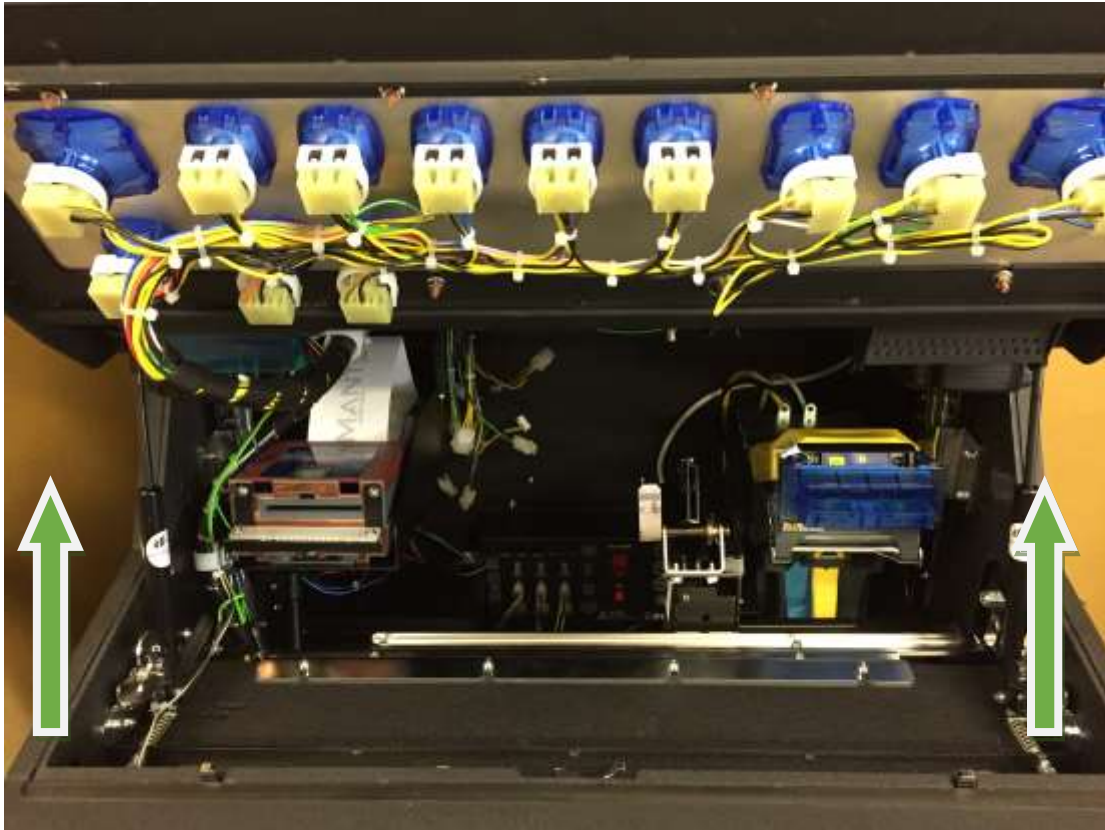

Figure 23: Button panel open position

12 Monitors

12.1 Position in the machine



Figure 24: Monitors position in machine

12.2 Function

Monitors show game play, error messages and audit system.

12.3 Troubleshooting

Check whether monitors and cable connectors are properly fixed in their mounting.

12.4 Monitor replacement

If there are defects that cannot be repaired, the defective monitor has to be replaced.

5. Unplug the machine and open the monitor door;
6. Unscrew the screws as shown in the picture (with red arrows).
7. Slightly unscrew the screws as shown in the picture (with white arrows) and move to the monitor edge (shown with yellow arrows).
8. Remove the monitor;



Figure 25: Monitor replacement

13 Audio amplifier

13.1 Function

Type **Grantech 4.1CH Audio Amplifier & SPDIF Board_Rev. A**

Audio Amplifier is mounted on the back wall of the machine, above DPRO main board.

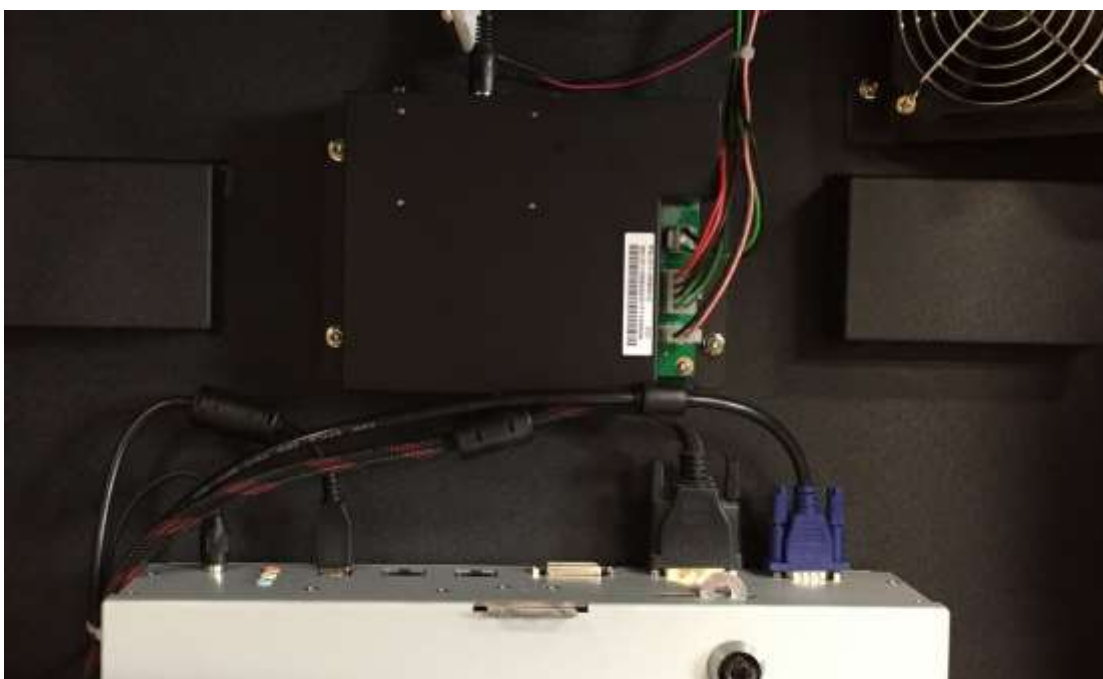

Figure 26: Audio amplifier position in machine

13.2 Error handling

1. Unplug the machine and open the monitor door
2. Check whether all connector cables are properly connected to the device

13.3 Replacement

If Audio amplifier cannot be fixed in-place, the complete device should be replaced.

1. Unplug the machine and open the monitor door
2. Disconnect all the wiring and unscrew four nuts that hold the audio amplifier in place (shown with red arrows).

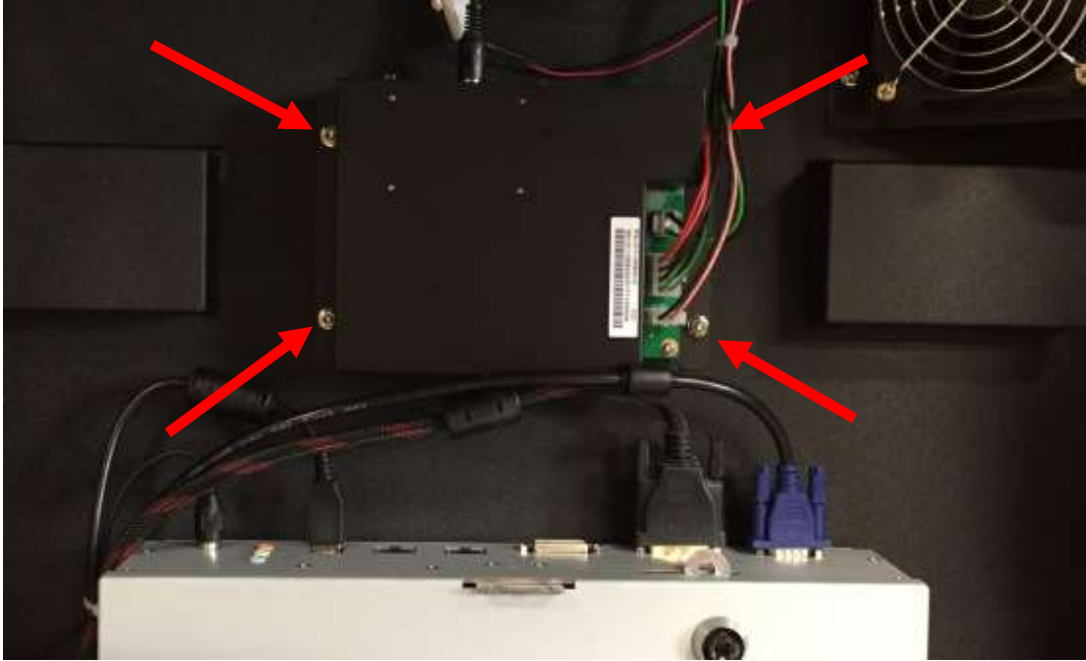

13.4 Connectors

A) Amplifier Board I/O & Control:

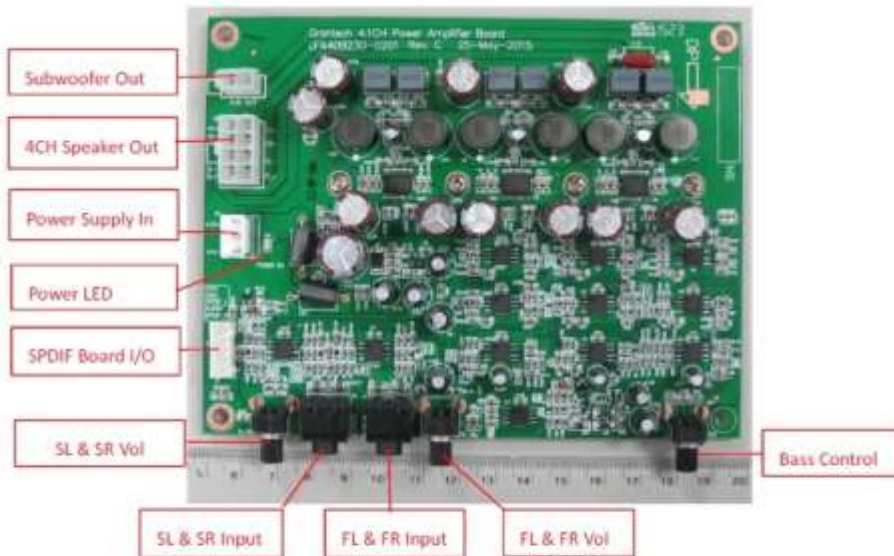

Fig1: Amplifier Board

1. **Power Supply In:** Operation Voltage 12 ~ 24VDC , 24VDC 5A Power Supply Input (Recommended)
2. **Power LED:** Power Supply Input , Green LED On
3. **SPDIF Board I/O:** Connected 24VDC to SPDIF and Analog stereo signal from SPDIF Board
3. **FL & FR Input:** Analog Front Left & Front Right Input Jack
4. **SL & SR Input:** Analog Surround Left & Surround Right Input Jack
(When SL & SR not Connected, FL & FR Signal will feed to SL & SR)
5. **4 CH Speaker Out:** FL , FR , SL & SR Speaker Output (20W/4ohm)
6. **Subwoofer Out:** 40W/8ohm Subwoofer Output.
7. **FL & FR Vol:** FR & RL Analog input level attenuator
8. **SL & SR Vol:** SR & SL Analog input level attenuator
9. **Bass Control:** ± 10dB Bass Boost & Cut control

Figure 27: Audio amplifier connector description

Amplifier Board Pin Assignment:



J1: Subwoofer Output Connector

J2: SPDIF Board Connector



J3: Power Supply Input Connector

J6: 4 CH Speaker Output Connector

B) SPDIF BOARD I/O and Control:

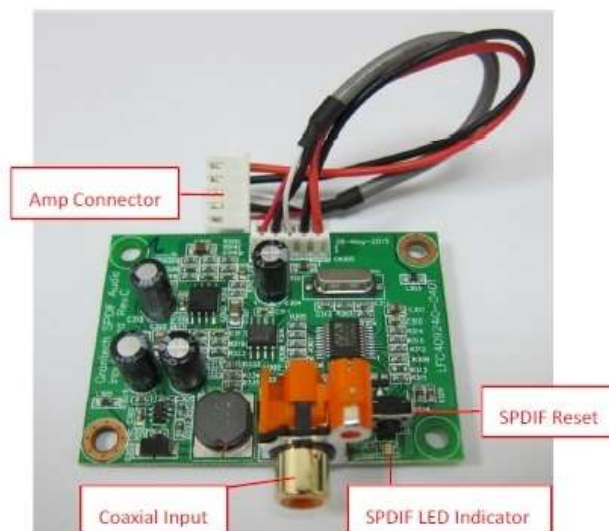

Fig2: SPDIF Board

1. **Coaxial Input:** Support Audio PCM Format Only
2. **Amp Connector:** Connect to Amplifier Board
3. **SPDIF Reset:** SPDIF Receiver Chip Reset
4. **SPDIF LED Indicator:** Green >> PCM , Red >> Non PCM

Figure 28: Audio amplifier connectors pin layout

14 LED control board

14.1 Function

Type

RGB Rendering board

This control board is intended to provide the machine with external illumination. LED Control Board is mounted between the monitors.

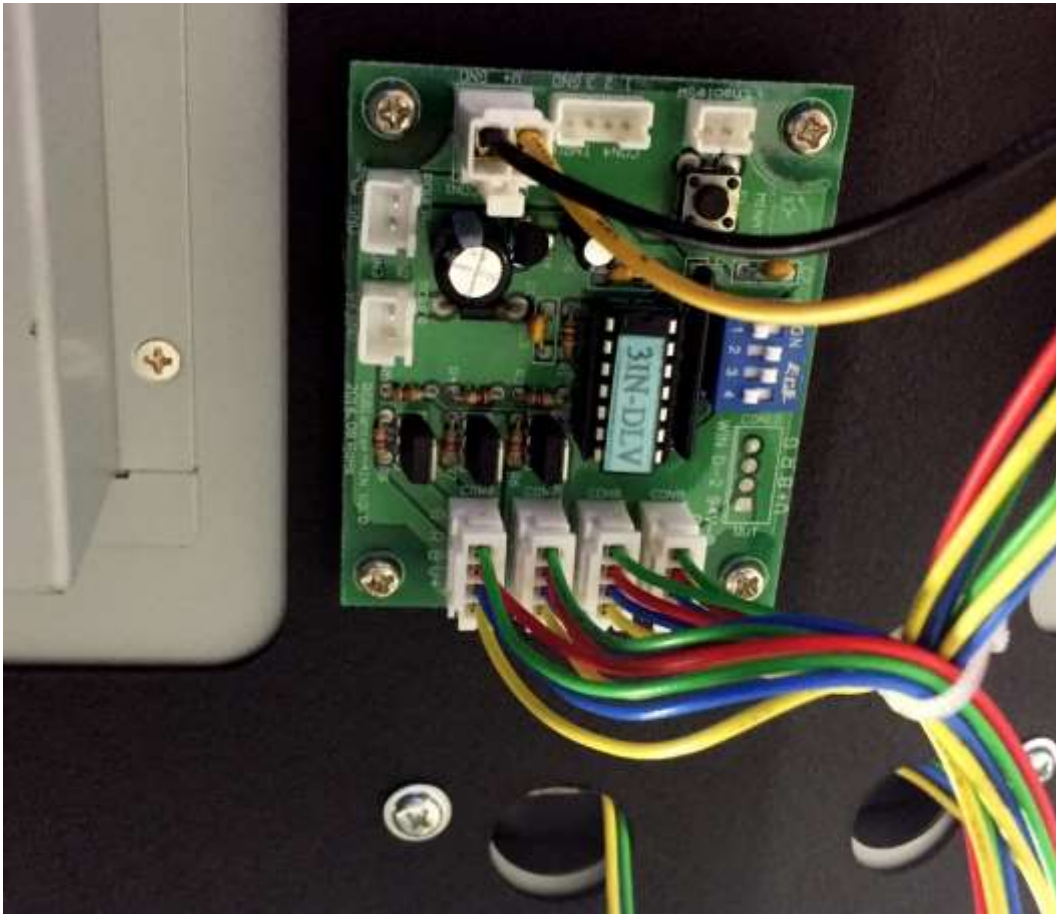

Figure 29: LED control board position in machine

14.2 Connectors

COM1, COM2 Output Port

- PIN1=Vcc+12V
- PIN2=B
- PIN3=R
- PIN4=G

COM4 INPUT Mode Selection

- PIN1=SW1
- PIN2=SW2
- PIN3=SW3
- PIN4=GND

COM5, COM6, COM7 POWER IN

- PIN1=Vcc+12V
- PIN2=GND

COM3 TEST SW

- PIN1=TEST SW
- PIN2=GND

Mode Selection:

COM4 Pin Count				Program
4	3	2	1	
COMMON	OPEN	OPEN		Brightness: High
	OPEN	SHORT		Brightness: Medium
	SHORT	OPEN		Brightness: Low
			OPEN	Full Color Rendering
			SHORT	Cold Color Rendering (Blue, Purple, White Shortly)
Leave Pin1 as open, choose brightness by Pin2 & pin3				

Table 10: LED PCB Mode Selection

15 Gaming platform D-PRO board

15.1 Function

Type D-Pro Main Board is an industrial PC-based processor board provided with high-performance embedded graphics, audio controller, network adapter, mSATA socket, etc.

The Gaming Platform Board is a complete all-in-one solution designed to suit all the gaming needs. The platform consists of a Chassis and a Main board.

The Gaming Platform Board is mounted on the back wall of the machine, behind the monitor door.

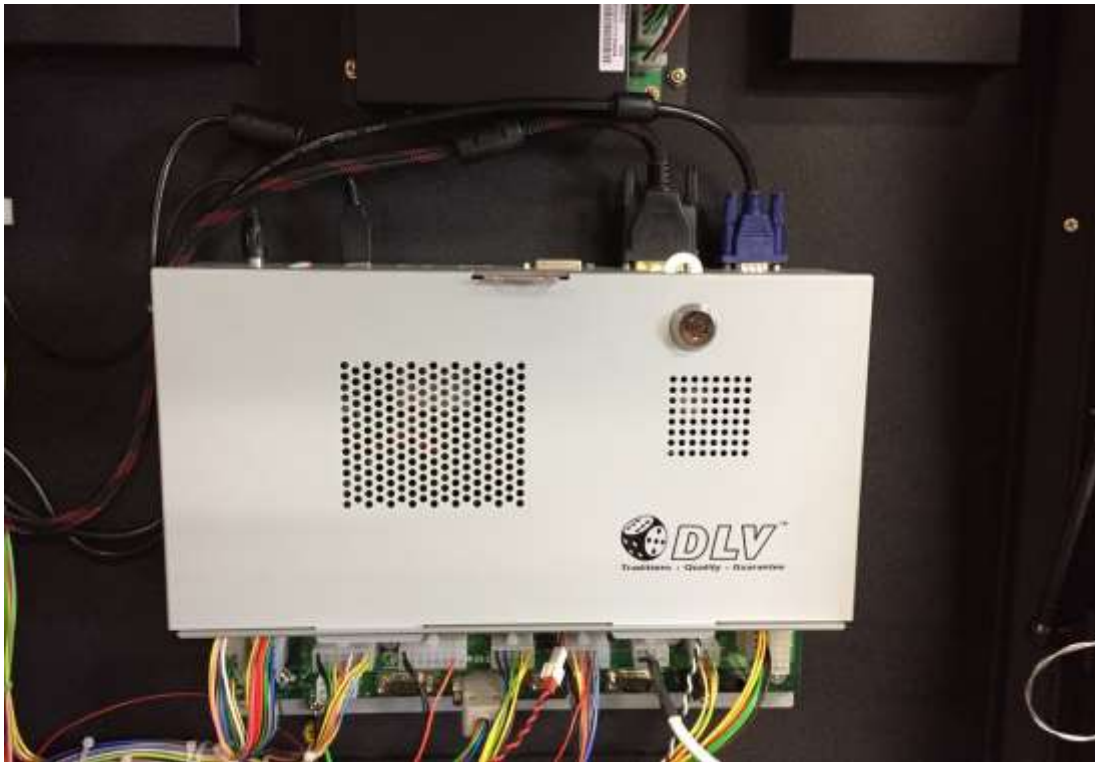

Figure 30: Gaming platform board position in machine

WARNING:

The main board contains two fans and a chassis - several holes for ventilation purposes. Fan speed is software-controlled. Ventilation holes should remain uncovered.

15.2 Error handling

1. Unplug the machine and open the monitor door
2. Check whether all connector cables are properly connected to the device
3. Check whether the power voltage is + 12V and the LED is on.

15.3 Replacement

If D-Pro Main Board cannot be fixed in-place, the complete device should be replaced.

1. Unplug the machine and open the monitor door
2. Disconnect all the wiring and unscrew 2 nuts that hold the Main Board in place (shown with red arrows).

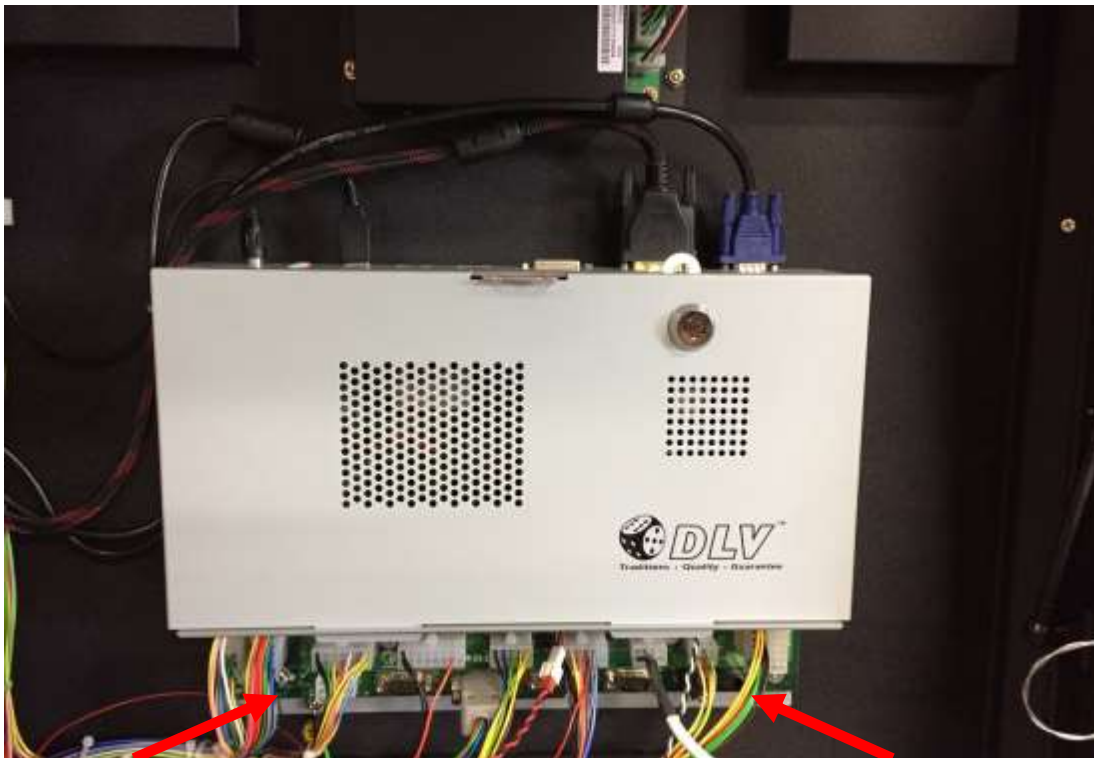

Figure 31: Gaming platform board replacement

16 Harness

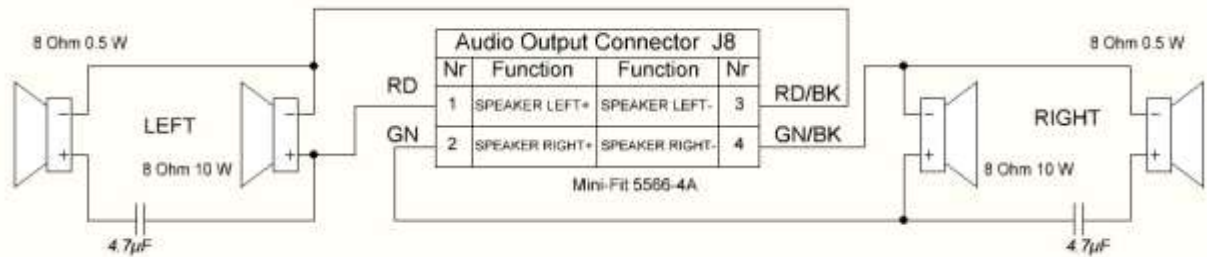

Figure 32: Audio connector

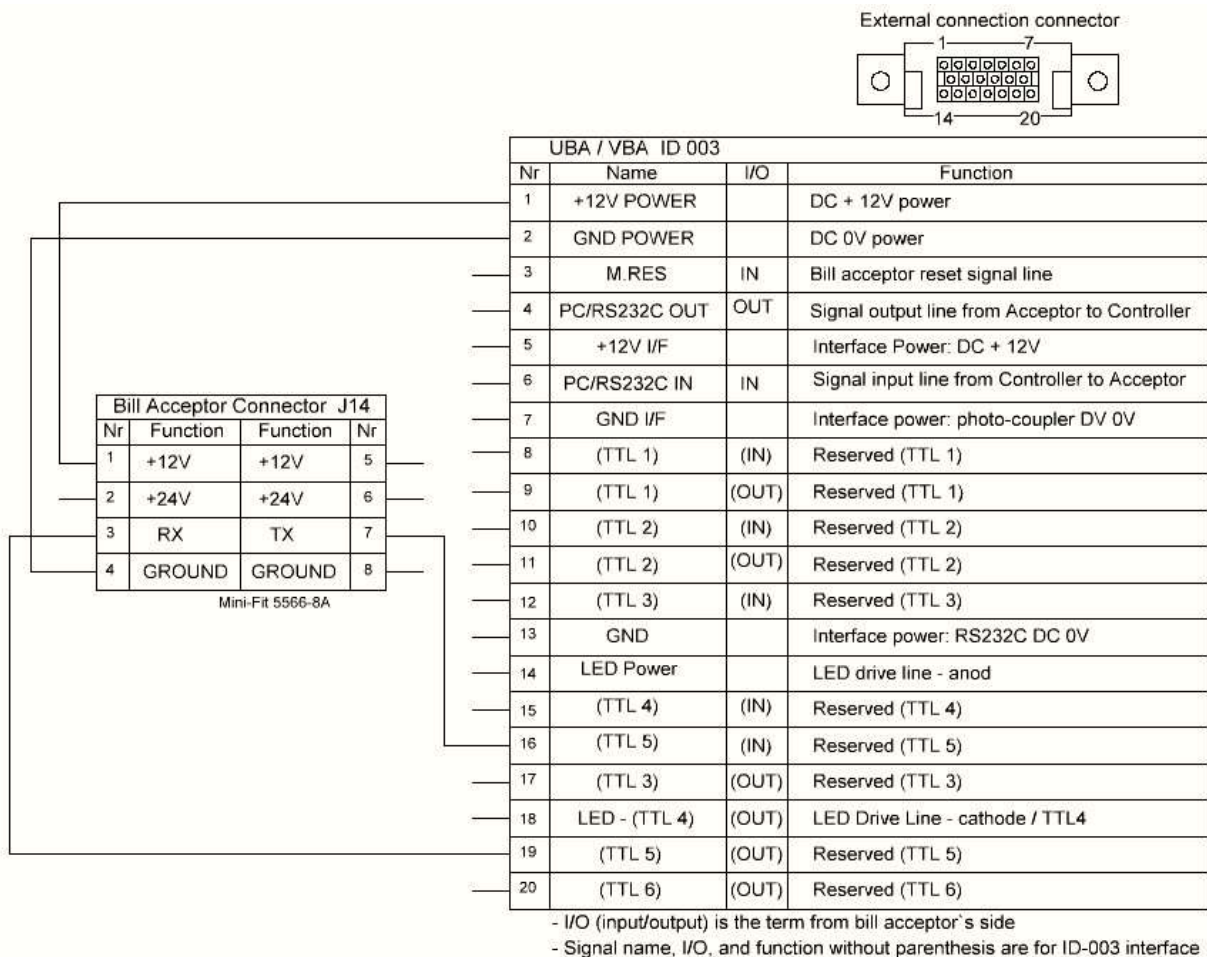

Figure 33: JCM UBA10 connector

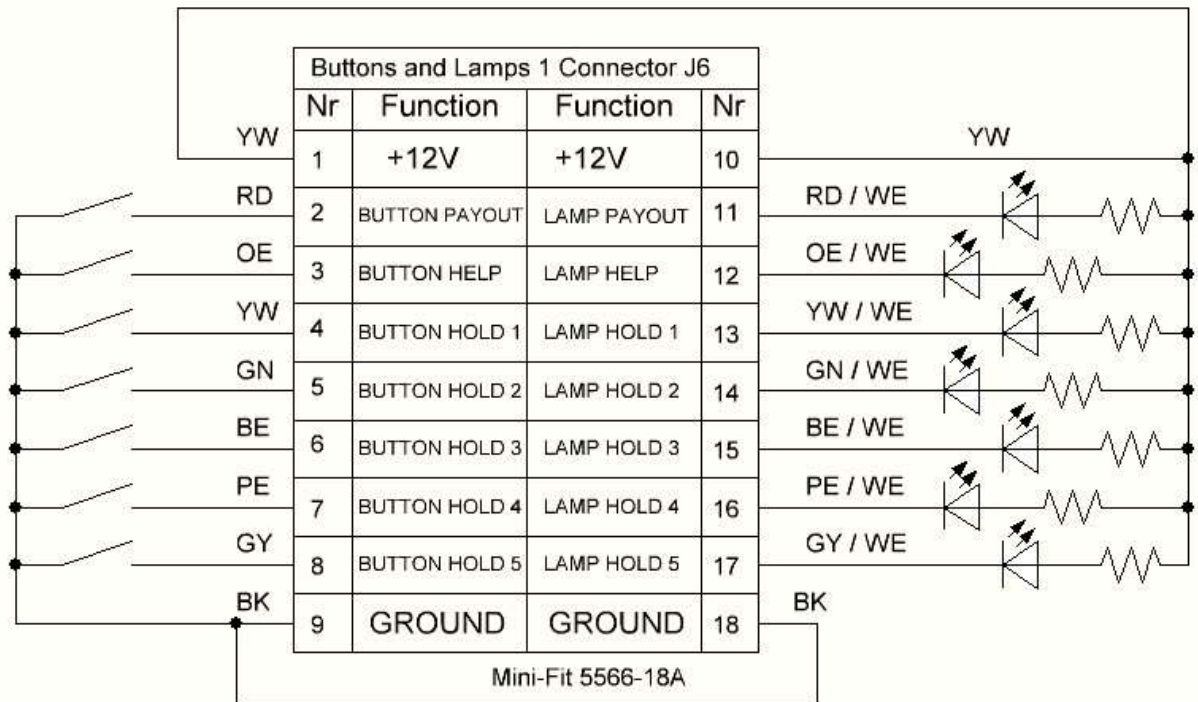

Figure 34: Button and lamp connector 1

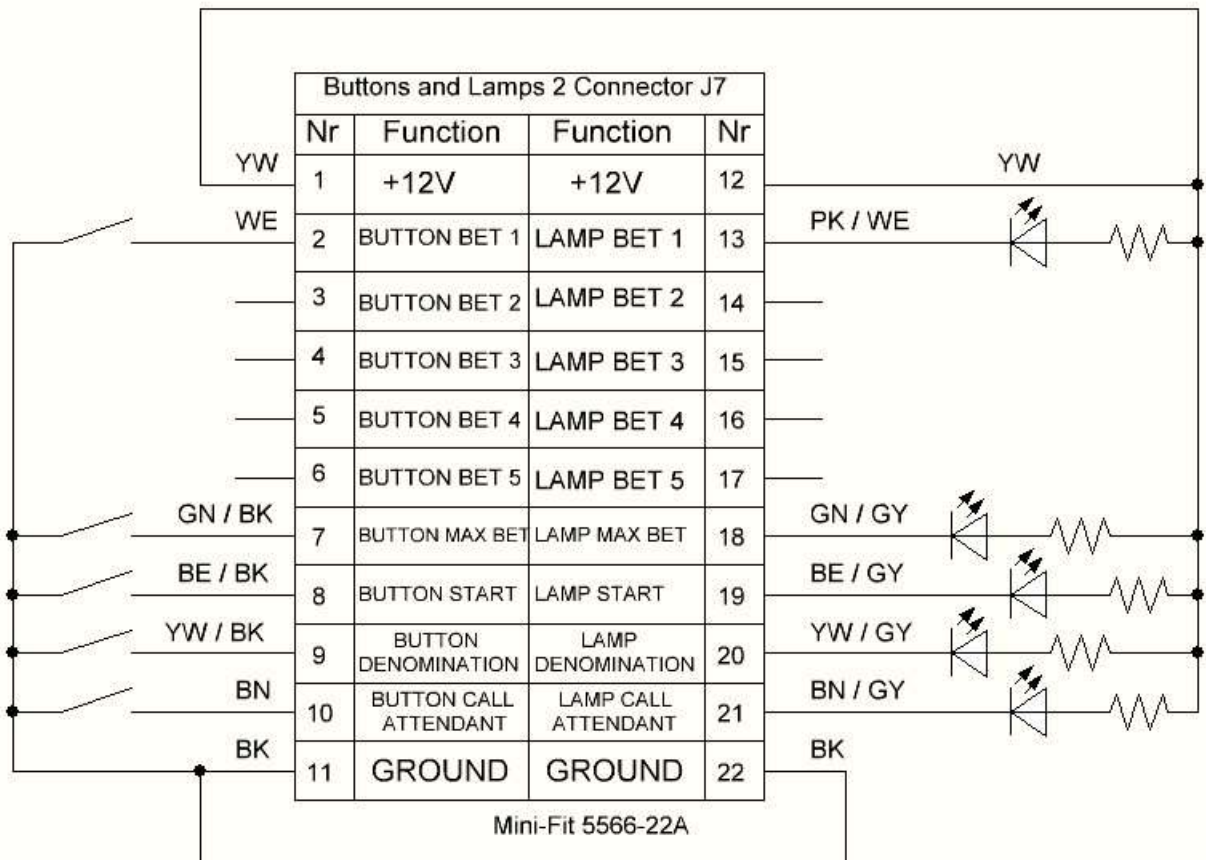

Figure 35: Button and lamp connector 2

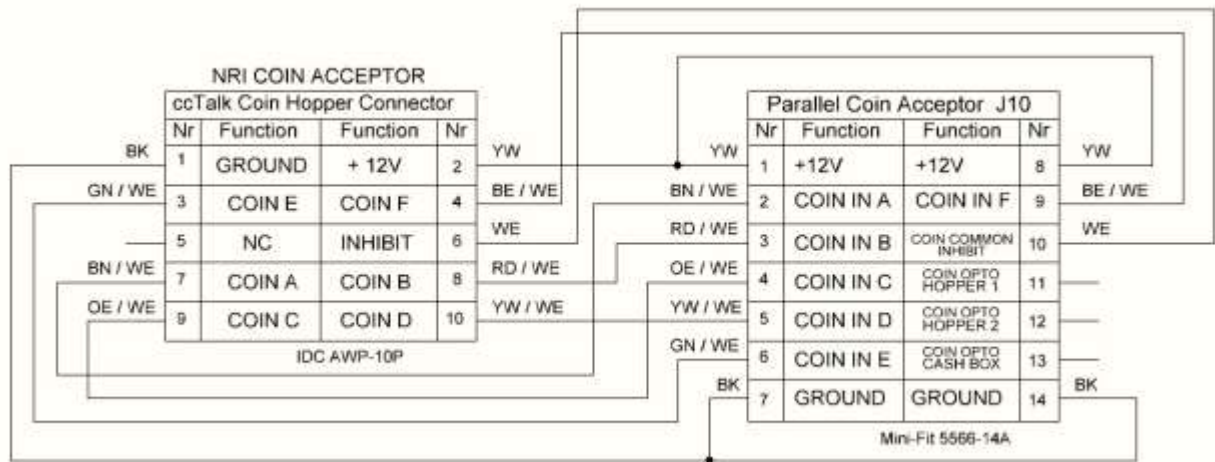

Figure 36: Coin acceptor connector

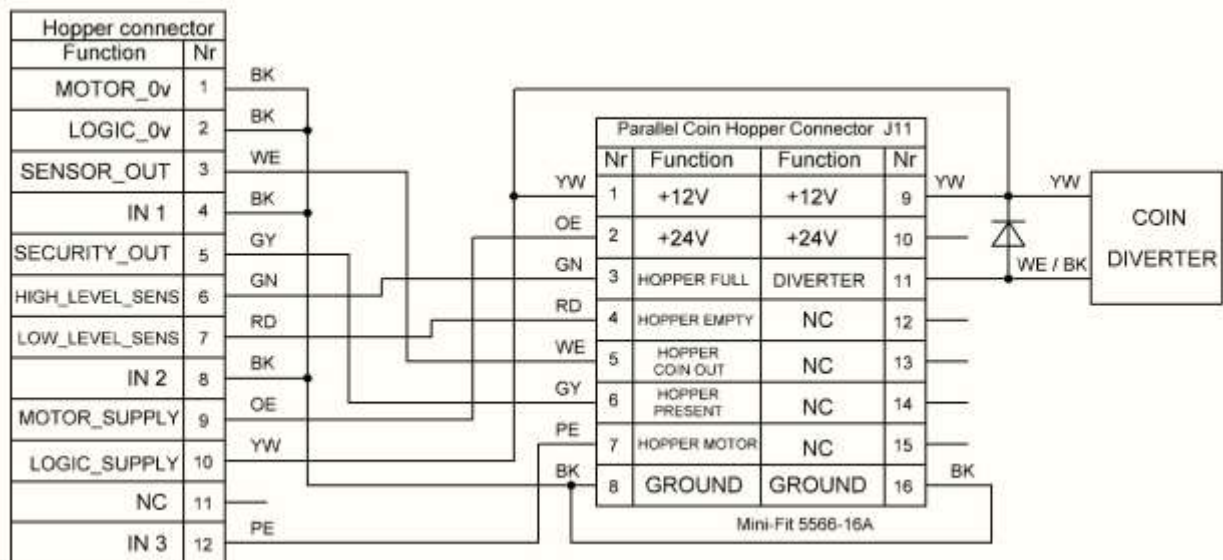

Figure 37: Coin hopper connector

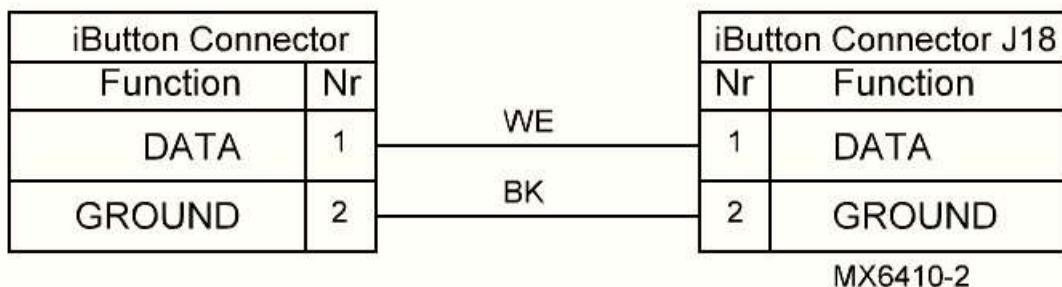

Figure 38: iButton connector

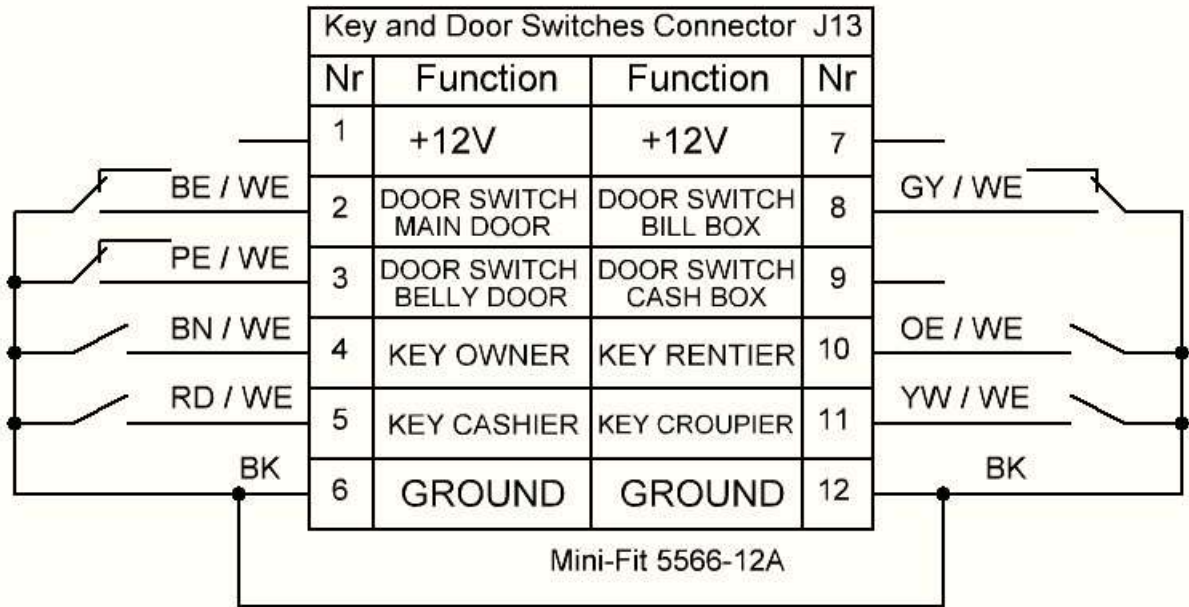

Figure 39: Key and door switch connector

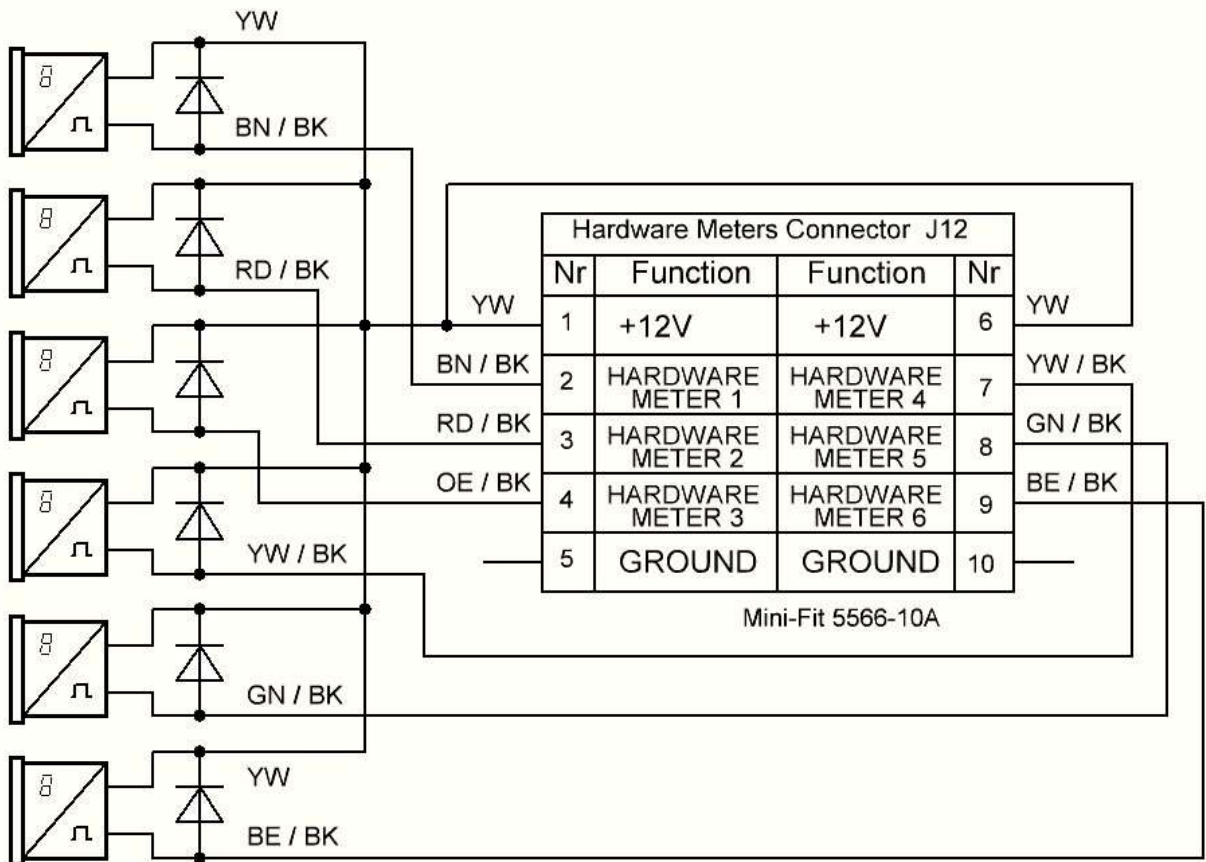

Figure 40: Hardware meter connector

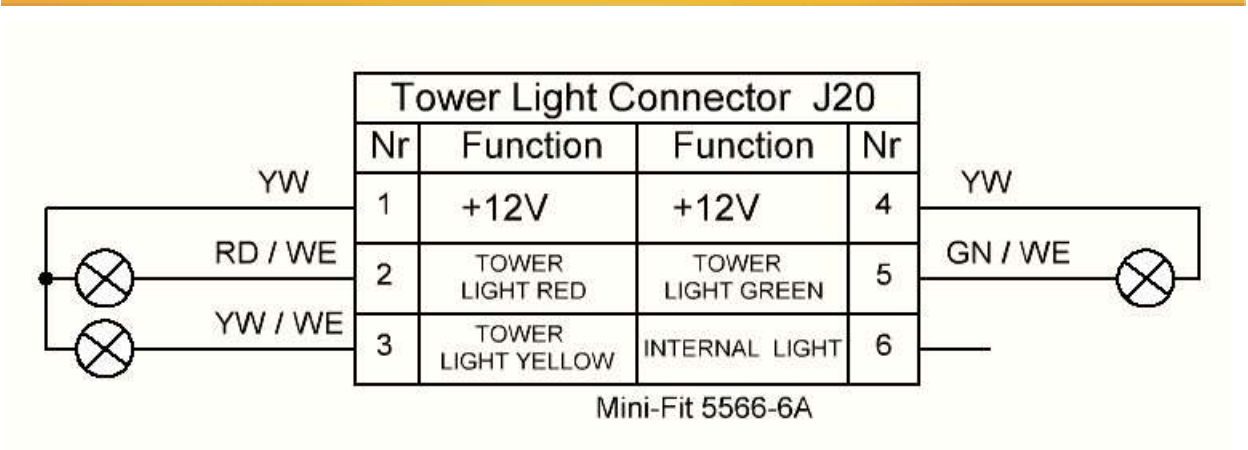
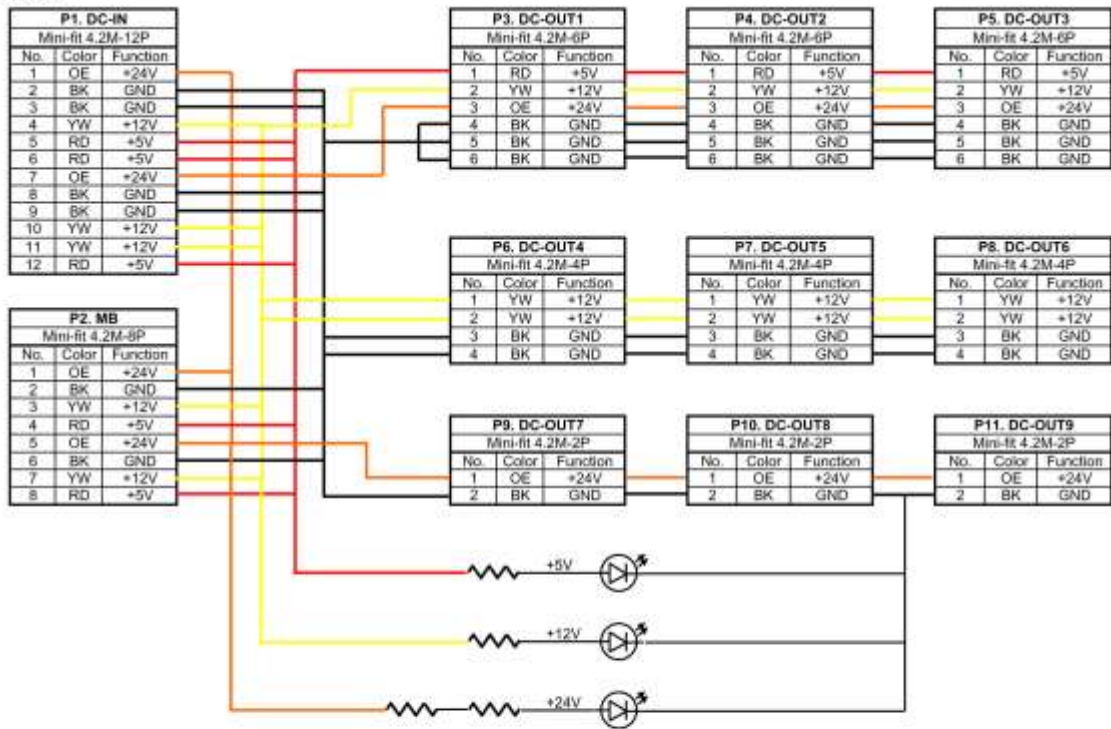

Figure 41: Top light connector

DC Connection:



cc-talk Connection:



AC Connection:

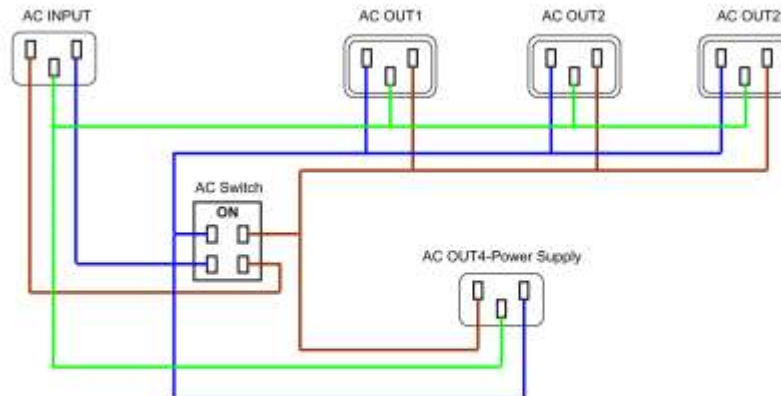

Figure 42: Power supply unit connector